

MONITOR BOOSTER STATIONS

POTABLE WATER LINE PRESSURIZING | POTABLE WATER TANK FILLING | GOLF COURSE IRRIGATION



TURF OR AGRICULTURAL IRRIGATION | NON-POTABLE WATER TRANSFER | FIRE PROTECTION | SNOW MAKING

- NO CONFINED SPACE ENTRY
- NO NOISE
- NO BUILDING
- SMALL FOOTPRINT
- EFFICIENT ENERGY USAGE
- SERVICEABLE
- EASY MAINTENANCE
- SAFE



NSF 61
CERTIFIED





MONITOR BOOSTER STATIONS

APPLICATIONS

- Potable Water Line Pressurizing
- Potable Water Tank Filling
- Golf Course Irrigation
- Turf or Agricultural Irrigation
- Non-Potable Water Transfer (Grey Water)
- Fire Protection
- Snow Making

The Monitor Booster Station is an economical and safe solution for increasing water line pressure or filling water storage tanks. The Monitor in-line Pitless Booster houses a submersible pump and motor below ground in the low pressure suction tank reservoir. The unique design eliminates the need for a costly pump house and removes the hazard of confined space entry. With the submersible electric motor located below grade, unwelcoming motor noise has been eliminated.

The Monitor Booster Station is custom designed for each application. Simplex stations can accommodate flows ranging from as little as 5 gallons per minute to large flow rates of 5000 gallons per minute. Duplex stations add redundancy where required by code or additional flow capacity is desired. Additional pitless boosters can be added as needed to accommodate flow rates as high as 30 million gallons per day.

Our Monitor Booster Stations are controlled by intelligently designed Variable Frequency Drive control systems. We utilized custom designed Ladder Logic control software to virtually eliminate the problem of water hammer and offer the smoothest pump operation in the industry.

The Monitor Pitless Booster Stations are scalable for future needs. An established system can be upgraded by increasing the pump size and reprogramming the controls. This offers our customers the option to meet future water pressure and volume requirements, without having to invest in a new booster system.

Did You Know? Monitor Water Systems can customize any of our products to adapt to your water system needs.



REAL WORLD APPLICATION

Machias Pump Station • Lake Stevens, WA

- Large Flow Pump Station
- Five Monitor PS1618 Booster Stations
- VFD Control Panel
- Total combined pumping capacity of 13 mgd

Larkspur Pump Station • Crested Butte, CO

- Residential fire protection and irrigation pump station
- Two Monitor PS810 Booster Stations and two PS1214 Booster Stations
- VFD Control Panel
- Total combined pumping capacity of 3 mgd



PITLESS BOOSTER STATIONS



Watertight Seal Cap

Designed to prevent surface contaminants from entering the upper casing portion of the pitless booster, the Watertight Seal Cap is the only visible, above grade, portion of the unit. Optional locking features are available for upper casing sizes 10" and above.

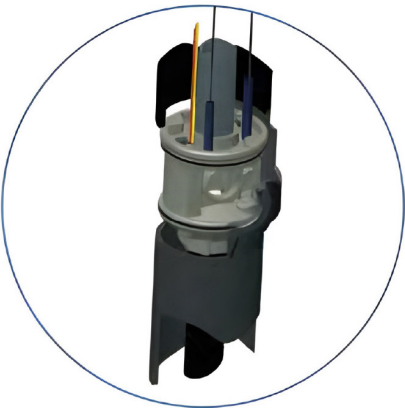

Spool / Discharge Body

The spool is the connection and turning point for the high pressure water coming from the submersible pump. Two o-rings seal the high pressure water within finely machined o-ring lands. Tappings located on the top side of the spool allow access to the suction and discharge pressure. Pressure transducers, located on the top of the spool, allow for continuous pressure readings in constant pressure applications. Pump wires are sealed using high pressure wire grommets.

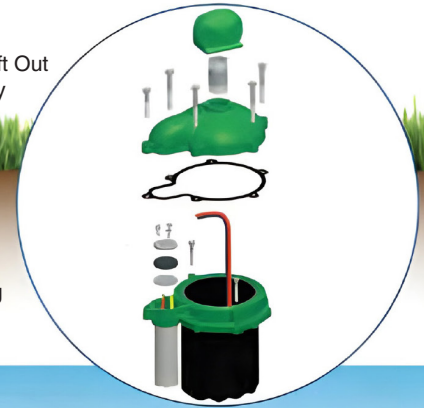
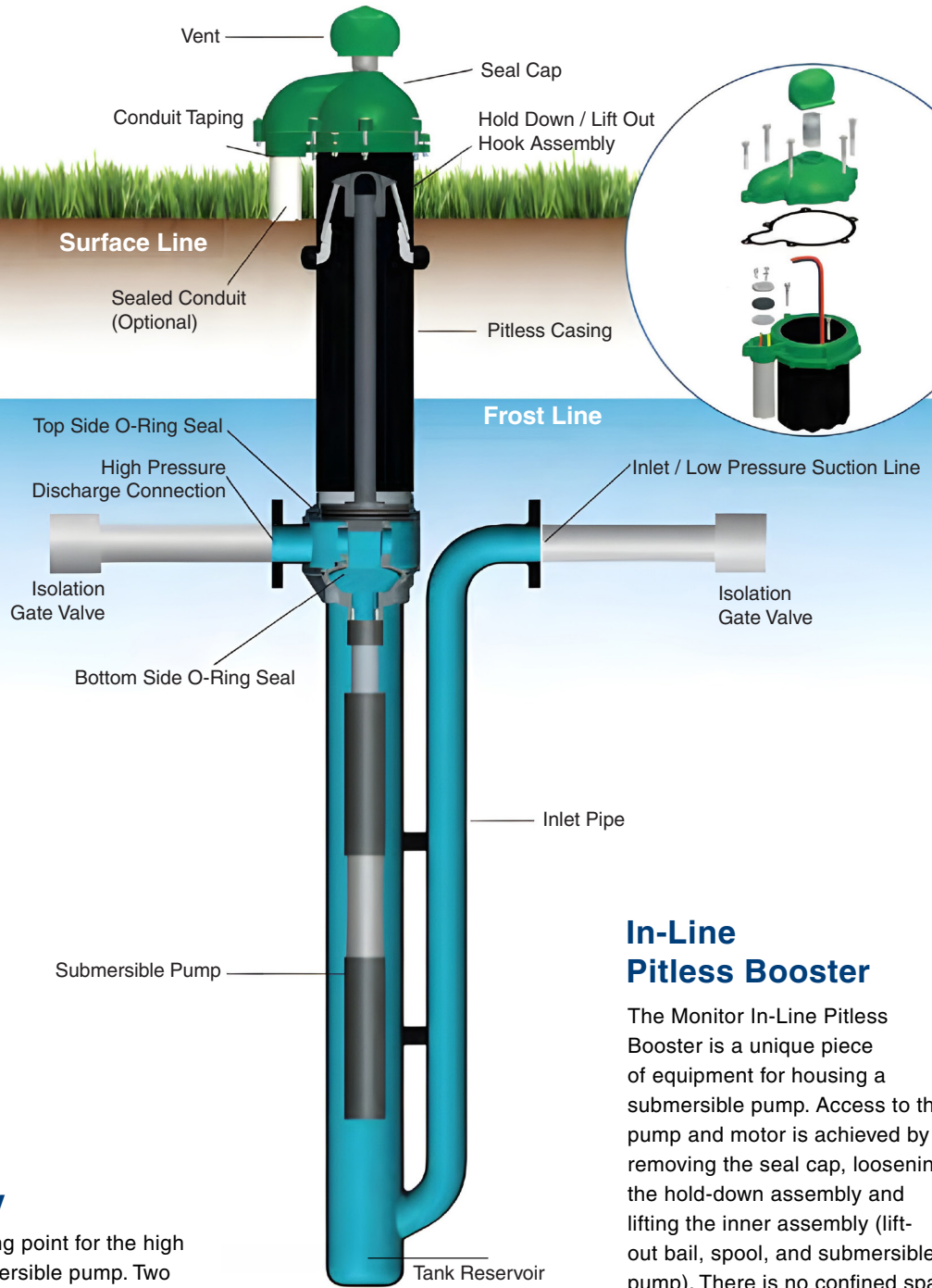

In-Line Pitless Booster

The Monitor In-Line Pitless Booster is a unique piece of equipment for housing a submersible pump. Access to the pump and motor is achieved by removing the seal cap, loosening the hold-down assembly and lifting the inner assembly (lift-out bail, spool, and submersible pump). There is no confined space entry as the unit is completely serviceable from above grade. Because the motor is located below grade, motor noise is virtually eliminated.

Did You Know? Monitor Water Systems can customize any of our products to adapt to your water system needs.

BOOSTER LAYOUT OPTIONS

The combination and customization possibilities of the Monitor Booster Stations are endless. Here are a few examples of the flexibility provided by the Monitor Booster Station to properly suit your project requirements:

SIMPLEX

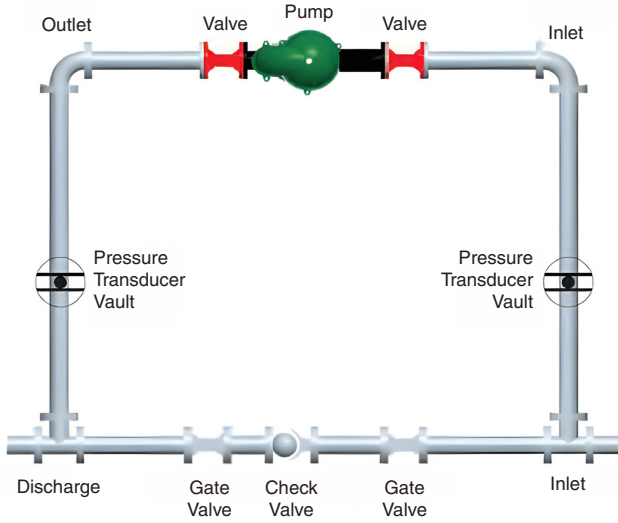

DUPLEX

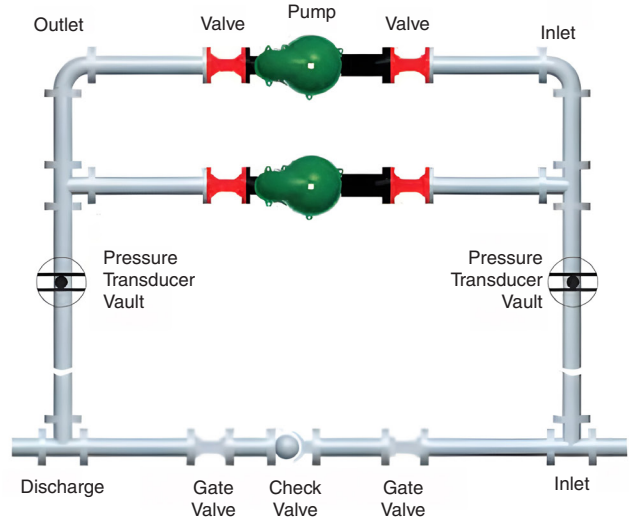

TRIPLEX

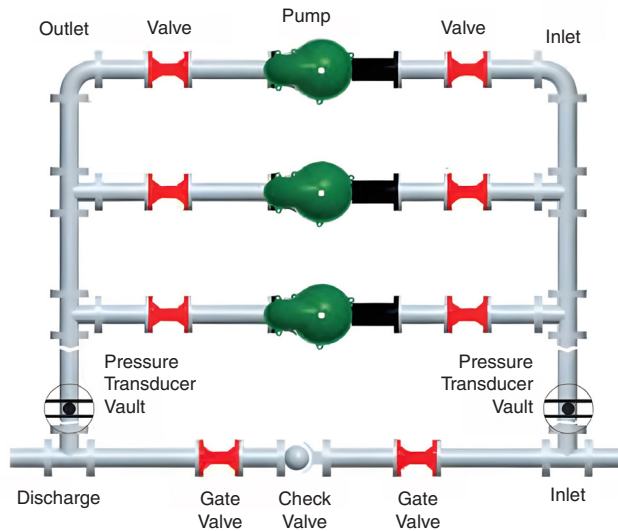

QUAD

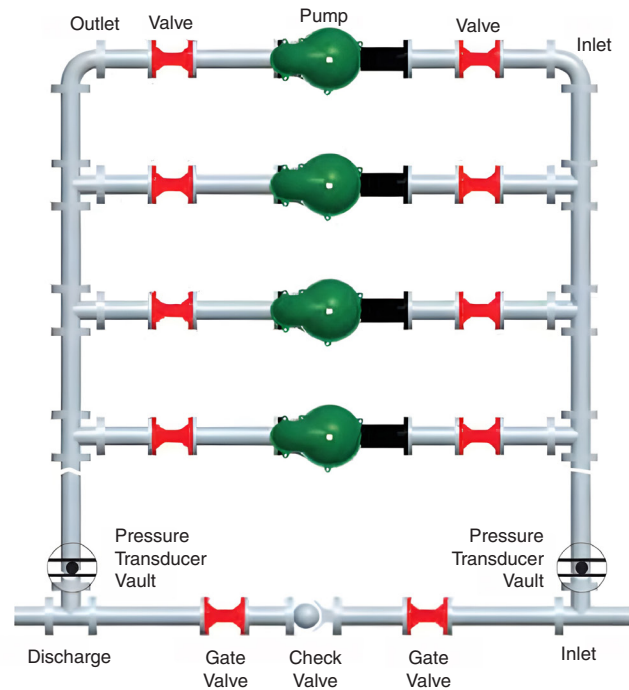

Did You Know? Did You Know? Monitor Water Systems also carries a full line of residential products.

MONITOR VFD CONTROL PANELS

Monitor offers fully functional, factory tested, UL approved, Variable Frequency Drive (VFD) and Constant Speed control panels. Our control panels are custom designed and built to suit each project. The difference is in the control software. Our VFD control panels utilizing Programmable Logic Controllers are distinctly different than most control panels in that we use custom designed Ladder Logic Control Software for better overall station performance, less wear on the pumps and motors, and virtual elimination (with exception of a power failure) of water hammer. Each control panel can be customized to display information and read-outs important to the customer. If you can describe it, we can program it into our control panels.



STANDARD PITLESS BOOSTER SIZES AND CONSTRUCTION MATERIALS:

Cast Iron, Lead Free Galvanized, Spool and Discharge Body, ASTM Certified Steel Upper Casing and Tank Reservoir.

- Monitor PS56 Pitless Booster – for 4" diameter submersible pumps
- Monitor PS67 Pitless Booster – for 5" or smaller diameter submersible pumps
- Monitor PS810 Pitless Booster – for 6" or smaller diameter submersible pumps
- Monitor PS1012 Pitless Booster – for 8" or smaller diameter submersible pumps
- Monitor PS1214 Pitless Booster – for 10" or smaller diameter submersible pumps
- Monitor PS1618 Pitless Booster – for 12" or smaller diameter submersible pumps

Cold-Rolled Steel Fabricated, Lead Free Galvanized, Spool and Discharge Body, ASTM Certified Steel Upper Casing and Tank Reservoir.

- Monitor PS1820 Pitless Booster – for 14" or smaller diameter submersible pumps
- Monitor PS2022 Pitless Booster – for 16" or smaller diameter submersible pumps
- Monitor PS2426 Pitless Booster – for 18" or smaller diameter submersible pumps
- Monitor PS2628 Pitless Booster – for 20" or smaller diameter submersible pumps
- Monitor PS3036 Pitless Booster – for 22" or smaller diameter submersible pumps
- Monitor PS3638 Pitless Booster – for 26" or smaller diameter submersible pumps

"My clients are very pleased with the Monitor Booster Station because it is a simple, low cost solution for their low pressure problems. We look forward to working with you on future projects."

Bobby R. Lane, PE
President
The Lane Group

Questions? Not seeing what you are looking for? Please call Monitor Water Systems at 800-356-5130.



WATER SYSTEM PRODUCTS

PROJECT TYPE:

- POTABLE WATER
 IRRIGATION
 NON-POTABLE WATER
 SNOW MAKING
 FIRE PROTECTION
 OTHER (SPECIFY): _____

BOOSTER STATION MAIN FUNCTION:

- PRESSURIZING A LINE
 FILLING TANKS
 OTHER (SPECIFY): _____

NUMBER OF BOOSTING STATIONS REQUIRED:

- SINGLE
 DUPLEX
 TRIPLEX
 QUAD
 OTHER (SPECIFY): _____

POTABLE WATER TOTAL DYNAMIC HEAD (FT): _____	POWER SOURCE: <input type="checkbox"/> SINGLE PHASE <input type="checkbox"/> THREE PHASE
REQUIRED FLOW RATE (GPM): _____	VOLTAGE: _____
INLET SUCTION PRESSURE (PSI): _____	INCLUDE BLADDER TANK: <input type="checkbox"/> YES <input type="checkbox"/> NO
DESIRED DISCHARGE PRESSURE (PSI): _____	FIRE FLOW REQUIREMENTS: <input type="checkbox"/> YES <input type="checkbox"/> NO
INLET SUCTION PIPE DIAMETER (IN): _____	REQUIRED INLET BURY DEPTH (FT): _____
DISCHARGE PIPE DIAMETER (IN): _____	REQUIRED DISCHARGE BURY DEPTH (FT): _____
CONTROL PANEL LOCATION: <input type="checkbox"/> INDOOR <input type="checkbox"/> OUTDOOR	CONTROL TYPE: <input type="checkbox"/> VFD <input type="checkbox"/> ACROSS THE LINE <input type="checkbox"/> SOFT START
INSTALLATION ALTITUDE _____	_____

Project	Customer Name	Engineering Firm
Date	Customer Email	Engineering Contact
Quote Due Date	Customer Phone	Engineering Contact Email
Project Number	Customer Fax #:	Engineering Phone #
		Engineering Fax #

NOTES/SPECIAL REQUIREMENTS: _____

WHY MONITOR?

- Simple, Safe, Quiet, Cost Effective, Easy to Maintain...and more
- Monitor provides conceptual design assistance and budget pricing proposals
- On-site start-up and training services
- Custom designed control software for effective utilization of power, elimination of water hammer and better overall station performance



BRIEF HISTORY OF BAKER MANUFACTURING



Baker Manufacturing Company was founded in 1873. The founders of Baker Manufacturing Company, Almeron Eager and Alan S. Baker, were civil war history enthusiasts. When they needed a name for their newly formed water systems division of Baker Manufacturing Company, they decided to call it Monitor after the first ironclad warship, the USS Monitor. The indecisive battle amongst the USS Monitor and the CSS Virginia (formerly known as the USS Merrimack) began a new era in naval warfare. The battle of the two ferocious ironclad warships was the beginning of the end for wood and sail naval ships. Today, the Monitor Division of Baker Manufacturing Company, stands strong, just like the battleship did in 1862.



QUALITY, SERVICE & SOLUTIONS

VISIT OUR WEBSITE AT

WWW.BAKERWATERSYSTEMS.COM

for other quality filtration and water system products

Baker Manufacturing Company, LLC

133 Enterprise Street, Evansville, WI 53536

Phone: 800-356-5130

Fax: 608-882-3777



03/2026