

# V/S Series

## DuraMAC™ Booster System

## QUICK START GUIDE

### INSTALLATION AND OPERATION MANUAL

#### 1 PIPE

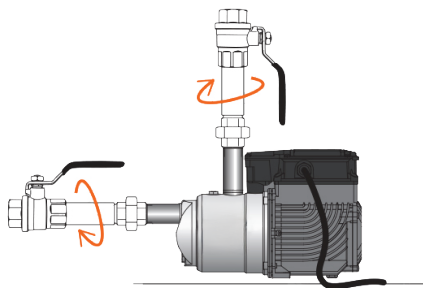

#### 2 PRIME

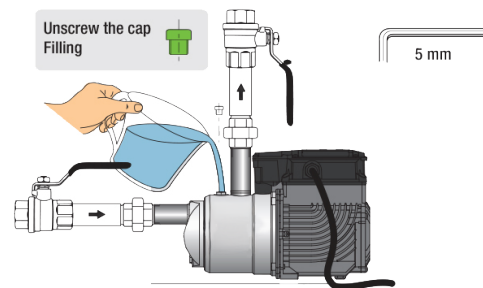

#### 3 PLUG & POWER

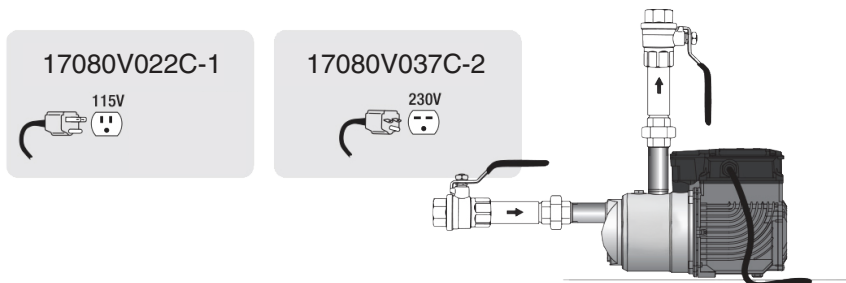

#### 4 SET PRESSURE

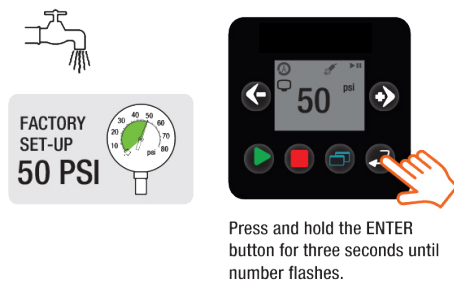

Consult the owner's manual as required for the cases detailed below.

- The pump is either cycling or does not shut off please go to page 15
- You want to set the working pressure above 80 psi, go to page 10, section 8.3
- If your pump will be working in a negative suction application (Lifting from a tank, pond, etc.) please go to page 10, section 8.3

**For Technical Questions**  
**Call 800-356-5130**



## ALARMS

Error reset can be automatic or manual, depending on the error that occurs. Manual reset is carried out using the enter button and then start to restart the pump.

CODE	DESCRIPTION	RESET ERR
Er01	Fault due to absence of water. Absence of water in the pump body.	MAN
Er02	Faulty pressure sensor	MAN
Er03	Fault due to low supply voltage	AUT
Er04	Fault due to high supply voltage	AUT
Er05	Fault due to number of starts exceeded	MAN
Er06	Fault due to overcurrent in the electric pump motor	MAN
Er07	Pump not fully primed	MAN
Er08	Fault due to internal overtemperature	AUT
Er09	Overpressure Fault	MAN
Er10	Intervention of the thermal protector detect	MAN
Er11	Fault due to air presence	MAN
Er30	Current imbalances	MAN
Er26 to Er29 and Er31	Internal hardware error	MAN

TABLE OF CONTENTS	PAGE
1. General Information	3
2. Technical Description	4
3. Technical Features	4
4. Safety	5
5. Transporting & Handling	5
6. Installation	5
7. Programming Guide	8
8. Start-Up & Operation	10
9. Maintenance	11
10. Disposal	12
11. Parts Breakdown	12
12. Alarms	13
13. Warnings	14
14. Troubleshooting	15

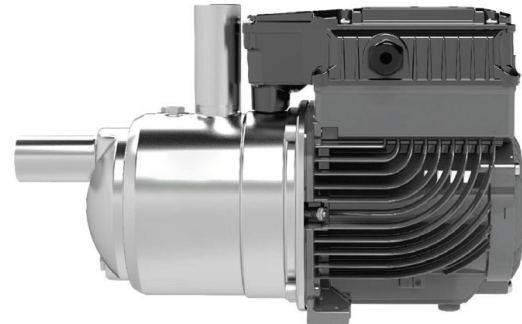

It is the user's responsibility to clean and maintain the appliance. Children should never clean or maintain it unless they are given supervision. Do not use in ponds, tanks or swimming pools or where people may enter or come into contact with the water.

Read carefully the installation:

- The maximum permissible structural working pressure (chapter 3.1).
- The type of electrical protection to be installed (chapter 6.5).

### 1.1. SYMBOLS

To improve the understanding of the manual, the symbols/pictograms indicated below, with their meanings, are used.



Information and warnings that must be observed, otherwise the machine could be damaged or personal safety could be compromised



Electrical information and warnings that must be observed, otherwise the machine could be damaged or personal safety could be compromised.



Notes and warnings for the correct management of the machine and its parts.



Operations that can be performed by the final user. After carefully reading the instructions, they are responsible for maintenance under normal conditions. They are authorized to perform routine maintenance operations.



Operations that must be performed by a qualified electrician authorized to perform all electrical maintenance and repair operations including maintenance. They are able to operate in the presence of high voltages.



Operations that must be done performed by a qualified technician capable of using the appliance correctly under normal conditions, authorized to perform all mechanical maintenance, adjustment and repair operations.



Indicates that it is mandatory to use personal protective equipment - hand protection



Operations that must be performed with the device switched off and disconnected from the power supply.



Operations that must be performed with the device switched on.

## 1. GENERAL INFORMATION

Before using the product carefully read the warnings and the instructions contained in this instruction manual, which should be kept for future reference. Italian is the original language of this instruction manual, this language is the reference language in case of discrepancies in the translations. This manual is part of the essential safety requirement of the appliance and must be retained until the product is finally de-commissioned.

The customer, in case of loss, can request a copy of the manual by contacting the manufacturer or their agent, specifying the type of product data shown on the label of the machine (see 2.3 Marking) Any changes, tampering or modifications made to the product or part of it, not authorized by the manufacturer, will revoke the "CE declaration" and warranty.

This appliance should not be operated by children, people with reduced physical, sensory or mental capacities, or inexperienced people who are not familiar with the product, unless they are given close supervision or instructions on how to use it safely and are made aware by a responsible person of the dangers its use might entail. Children must not play with the appliance.

## 1.2. MANUFACTURER INFORMATION

AY McDonald Pumps by Baker  
1809 Adel Street, Suite 110, Janesville, WI 53546  
Phone: (800) 356-5130 | BWS@baker-mfg.com

## 1.3. AUTHORIZED OPERATORS

The product is intended for use by expert operators divided into end users and specialized technicians. (see the symbols above).



It is forbidden, for the end user, to carry out operations which must be performed only by specialized technicians. The manufacturer declines any liability for damage related to the noncompliance of this warning.

## 1.4. WARRANTY

For the product warranty refer to the general terms and conditions of sale.



The warranty covers only the replacement and the repair of the defective parts of the goods (recognized by the manufacturer).

The Warranty will not be considered in the following cases:

- Whenever the use of the device does not conform to the instructions and information described in this manual.
- In case of changes or variations made without Manufacturer's authorization.
- In case of technical interventions carried out by a nonauthorized personnel.
- In case of failure to carry out adequate maintenance.

## 1.5. TECHNICAL ASSISTANCE

Any information regarding documentation or technical assistance can be requested from the manufacturer (paragraph 1.2).

## 2. TECHNICAL DESCRIPTION

Variable speed pressure boosting system with integrated control, complete with integrated pressure transducer that maintains system pressure even with variation in consumption.

For protection of the pump:

- Against dry running;
- Against the risk of operation without water at the inlet (caused by a lack of water inflow in the inlet pipe under the positive suction head, by a non-immersed suction pipe, by excessive suction lift or by air entering the suction pipe);

### 2.1. INTENDED USE

For clean water not containing abrasives, solids, or fibrous particles. Water temperatures from 32 - 95 degrees Fahrenheit.

### 2.2. REASONABLY FORESEEABLE MISUSE

The device is designed and built only for the purpose described in paragraph 2.1.



Improper use of the device is forbidden, as is use under conditions other than those indicated in these instructions.

Improper use of the product reduces the safety and the efficiency of the device, the manufacturer shall not be held responsible for failure or accidents due to improper use.



Do not use in ponds, tanks or swimming pools when there are people in the water.

## 2.3. MARKING

The following picture is a copy of the name-plate that is on the external case of the pump.



## 3. TECHNICAL FEATURES

### 3.1. TECHNICAL DATA

Dimensions and weight (see technical catalog).

Rated speed 4500 rpm (5800 rpm for VS Series 17080V022C-1) Protection IP X4

Supply voltage / Frequency:

115V~60Hz (VS Series 17080V022C-1)

230V~60Hz (VS Series 17080V037C-2)

Cable:

SJO 3X16 AWG, length 4,9 ft, with NEMA 5-15 plug (115V)

SJO 3X16 AWG, length 4,9 ft, with NEMA 6-15 plug (230V)

Check that the main's frequency and voltage correspond to the electrical characteristics shown on the plate.

The electric data marked on the plate to the rated power of the motor.

Sound pressure: < 70 dB (A).

Max. starts per hour: 90 at regular intervals.

Maximum permissible pressure in the pump casing: 277 ft (120 psi).

Max. inlet water pressure: PN (Pa) - Hmax (Pa) [14.5 psi = 100.000 Pa].

Maximum suction lift : 13 ft (9,8 ft for VS Series 17080V022C-1)

### 3.2. PUSHBUTTON FUNCTIONS

The user interface consists of a keyboard with 6 push buttons that each have a specific function described on this page.



Use this button to start the pump.



Use this button to stop the pump.



Use this button to access the product programming parameters. If already on the programming screen, press this button to go back to the previous menu.



3 sec

Use this button to access programming parameters. If you changed a parameter, by pushing this button you can confirm the indicated value. Use this button to reset the errors.



Use this button to decrease parameters or to change the displayed parameter.



Use this button to increase parameters or to change the displayed parameter.

### 3.3. OPERATING CONDITIONS

The unit should be installed in well ventilated location protected from the weather, with ambient temperature of +32°F to +104°F. Relative humidity: from 10% to 55% noncondensing.

### 4. SAFETY

#### 4.1. GENERAL RULES OF CONDUCT



Before using the product it is necessary to know all the safety indications.

Carefully read all operating instructions and the indications defined for the different steps: from transportation to disposal. The specialized technicians must carefully comply with all applicable standards and laws, including local regulations of the country where the pump is sold. The device has been built in conformity with the current safety laws. Improper use could damage people, animals and objects.

The manufacturer declines any liability in the event of damage due to improper use or use under conditions other than those indicated on the nameplate and in these instructions.



Follow the routine maintenance schedules and promptly replace damaged parts, this will allow the device to work in the best conditions.

Use only original spare parts provided by the manufacturer or by an authorized distributor.

Do not remove or change the labels on the device. Do not start the device if you notice defective or damaged parts

Maintenance operations, requiring full or partial disassembly of the device, must be performed only after disconnecting the device from the power supply.

#### 4.2. SAFETY DEVICES

The device has an external case that prevents any contact with internal and live parts.

#### 4.3. RESIDUAL RISKS

The appliance, when used according to its intended use and safety regulations, does not have any residual risks.

#### 4.4. INFORMATION AND SAFETY SIGNS

For this kind of product there will not be any signs on the product.

#### 4.5. PERSONAL PROTECTIVE EQUIPMENT

During installation, startup, and maintenance, the authorized operators are advised to use personal protective equipment. Safety gloves are required.



Sign personal protective equipment  
**HAND PROTECTION** (gloves for protection against chemical, thermal and mechanical risks).

### 5. TRANSPORTATION AND HANDLING

The product is packed to maintain the content intact. During transportation avoid stacking excessive weights. Ensure that during transportation the box cannot move. It is not necessary to use any special vehicle to transport the packaged device. The transport vehicles must comply, for the weight and dimensions, with the chosen product (see overall dimensions in technical catalog).

#### 5.1. HANDLING

Handle with care, the packages must not be subject to shocks. Avoid placing other material on the packages that could damage the pump. If the weight exceeds 55 lbs the package must be handled by two people at the same time.

#### 5.2. STORAGE

The appliance must be stored in a dry place, protected from shocks and preferably in its original packaging.

Respect the following storage conditions:

- Ambient temperature from 14°F to +122°F.
- Relative humidity: from 10% to 85% non-condensing.

### 6. INSTALLATION

#### 6.1. DIMENSIONS

For the dimensions of the device (see technical catalog).

#### 6.2. AMBIENT REQUIREMENTS AND INSTALLATION SITE DIMENSIONS

The customer has to prepare the installation site in order to guarantee correct installation and in order to fulfill the device requirements (electrical supply, etc...). The place where the device will be installed must fulfill the requirements indicated in paragraph 3.3. It is strictly forbidden to install the machine in an environment with a potentially explosive atmosphere.

### 6.3. UNPACKING

**i** Check the device for any damage that may have occurred during transportation.

The packaging materials, once removed, must be discarded/ recycled according to local laws in the country of destination of the device.

### 6.4. INSTALLATION

#### 6.4.1 EASY INSTALLATION

**1 PIPE**

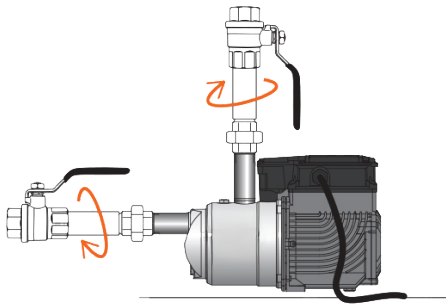

**2 PRIME**

Unscrew the cap Filling

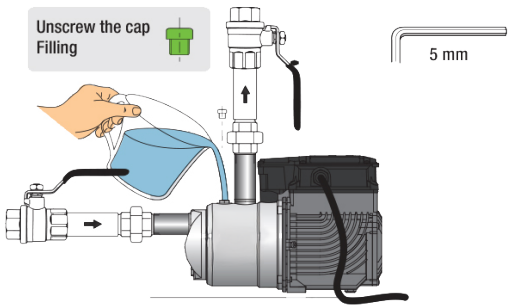

5 mm

**3 PLUG & POWER**

17080V022C-1 115V

17080V037C-2 230V

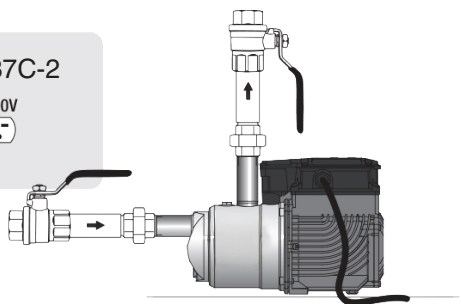

**4 SET PRESSURE**

FACTORY SET-UP 50 PSI

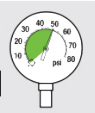

Press and hold the ENTER button for three seconds until number flashes.

MAX. SET PRESSURE 80 PSI

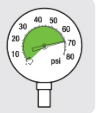

MIN. SET PRESSURE 26 PSI



Adjust the pressure using the + or - button. Then press ENTER

### 6.4.2 COMPLETE INSTALLATION

See installation examples, fig. 1 and 2. The pumps must be installed with the rotor axis in the horizontal position and with the feet under the pump. Place the pump as close as possible to the suction source.

Provide space around the pump for motor ventilation, for checking the direction of rotation of the shaft, for filling and draining the pump and to allow for the collection of the liquid to be removed.

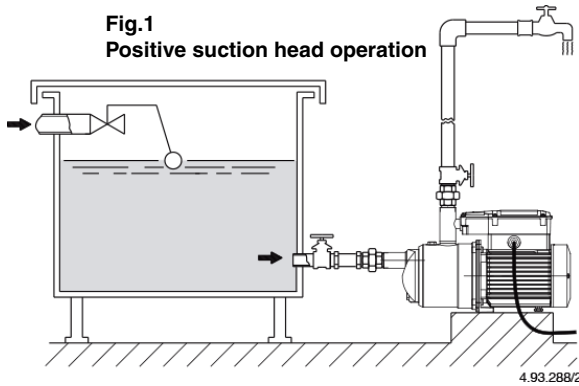

**Fig.1**  
Positive suction head operation

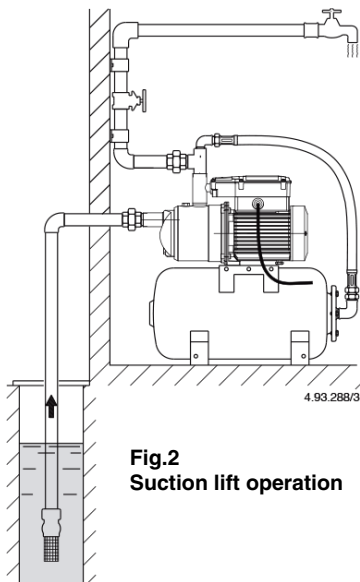

**Fig.2**  
Suction lift operation

### 6.4.3 PIPES

Make sure that the insides of the pipes are clean and unobstructed before connection.

**ATTENTION:** the pipes should be secured to their supports and connected in such a way that they do not transmit stress, strain or vibrations to the pump, fig. 3.

Tighten the pipes or union coupling to the extent sufficient to ensure a tight seal. Excessive tightening may cause damage to the pump. The pipe diameters must not be smaller than the pump connections.

### 6.4.4 SUCTION PIPE

The suction pipe must be perfectly airtight and be led upwards in order to avoid air pockets. With the pump located above the water level (suction lift operation, fig. 2, fit a foot valve with strainer which must always remain immersed.

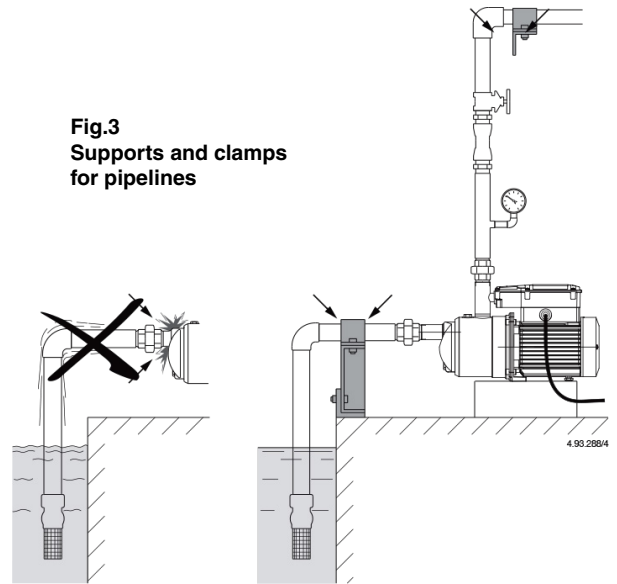

**Fig.3**  
Supports and clamps  
for pipelines

Use only rigid pipe and rigid pipe connections on the suction side of this pump. Flexible pipe and flexible pipe connections are not recommended on the suction side of this pump. With the liquid level on the suction side above the pump (inflow under positive suction head, fig. 1, fit an inlet gate valve.

**ATTENTION:** the pump is equipped with check valve built into the pump suction, in order to fill the suction pipe there must be a filling system on the suction pipe, fig. 4. Follow local specifications if increasing network pressure.

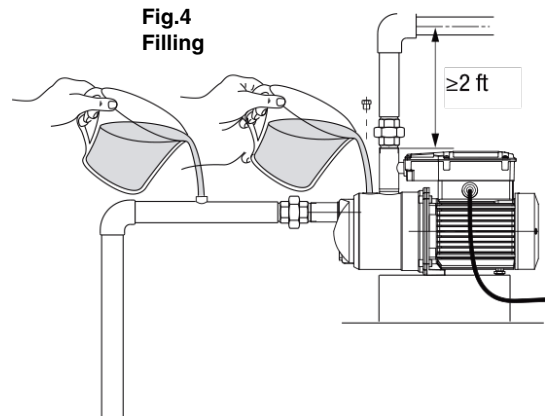

**Fig.4**  
Filling

### 6.4.5 DELIVERY PIPE

Fit a gate valve in the delivery pipe to adjust delivery and head. When the geodetic difference in level in the delivery section is over 50 ft, fit a check valve between the pump and the gate valve in order to protect the pump from water hammering.

**ATTENTION** It is necessary to check that the restart pressure (subtraction between UP01-UP02) is compatible with the actual pressure of the pump and of the water column of the system.

6.5. ELECTRICAL CONNECTION



Electrical connection must be carried out only by a qualified electrician in accordance with local regulations.

Always follow the National Electrical Code (NEC), or the Canadian Electrical Code, as well as all local, state and provincial codes. Code questions should be directed to your local electrical inspector. Failure to follow electrical codes and OSHA safety standards may result in personal injury or equipment damage. Failure to follow manufacturer's installation instructions may result in electrical shock, fire hazard, personal injury or death, damaged equipment, provide unsatisfactory performance, and may void manufacturer's warranty.



Install, ground and wire according to local and National Electrical Code Requirements.

Electrical supply **MUST** match pump's nameplate specifications. Incorrect voltage can cause fire, damage to the motor and voids the warranty. Pumps not protected **MUST** be provided with contactors and thermal overloads for single phase motors. See motor nameplate.

Use only copper wire to motor and ground. The ground wire **MUST** be at least as large as the wire to the motor. Wires should be color coded for ease of maintenance. Make sure that the frequency and main's voltage correspond to the values indicated on the plate.

For use in swimming pools (only when there are no people in the pool), garden ponds and similar places, an F-type residual current device with in not exceeding 30 mA must be installed in the supply circuit.

Install a device for disconnection from the main's (switch) with a contact separation of at least 0,12 inch in all poles. The pumps are supplied with a built-in thermal protector and with a plug. Connect the plug to a socket with an earth lead. The motor will stop if overheating is detected.

7. PROGRAMMING GUIDE

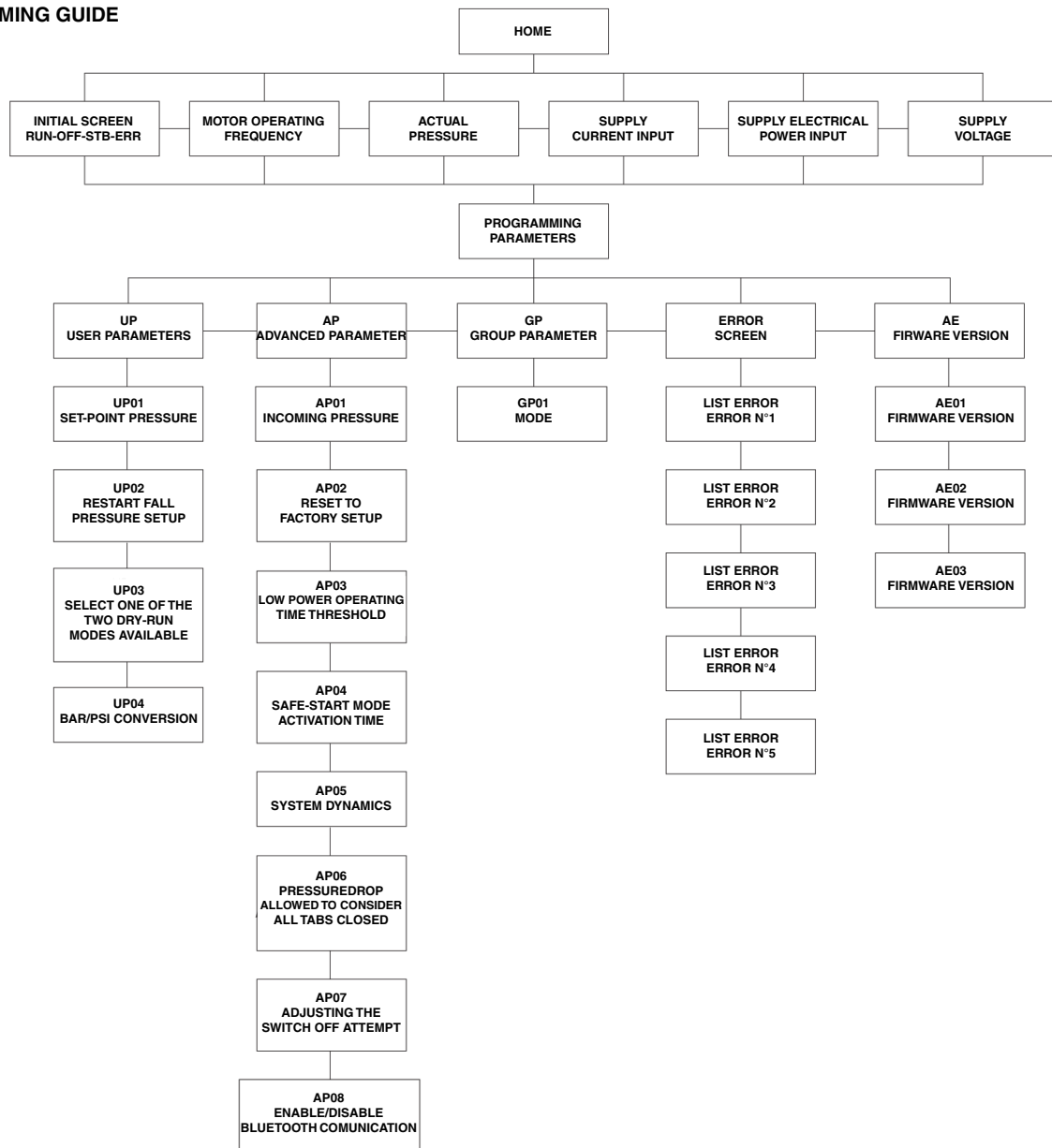

### 7.1. PARAMETERS

The following information is displayed:

- Pump status parameters.
- Programming parameters.
- Alarms.

### 7.2. PUMP STATUS PARAMETERS

They allow you to view:

- Initial screen (rUn, OFF, StB, Err).
- Motor operating frequency.
- Delivery pressure measured by the transducer.
- Supply current input.
- Supply electrical power input.
- Supply voltage.

Starting from the main screen, press the arrows (plus) or (minus) to view the other parameters.

### 7.3. PROGRAMMING PARAMETERS

To view the programming parameters, select (menu).

The following are displayed in succession:

**UP** – User settings: these are the basic settings that the user may change.

**AP** - Advanced settings: these settings are available only to qualified personnel. To enter, a password is required (see paragraph 7.6.).

**GP** – booster unit settings: to be set only if there is a booster unit.

**Err** - Last 5 alarms. In case of no error, nOnE appears.

**AE** - By means of the AE menu, you can identify the firmware installed.

Firmware=AE01+AE02+AE03.

### 7.4. PARAMETERS

The following parameters are available and programmable:

#### 7.4.1. UP – USER SETTINGS

PAR.	DESCRIPTION	VALUES	STANDARD
UP01	Set-point pressure (psi)	19÷50 PSI (VS Series 17080V037C-2) 19÷80 PSI (VS Series 17080V022C-1)	50
UP02	Restart fall pressure set-up (psi)	7÷50 (VS Series 17080V037C-2) 7÷54 (VS Series 17080V022C-1)	15
UP03	Select one of the two dry- run modes available	0,1	0
UP04	Management of pressure unit of measure (bar/psi)	0,1	0

#### 7.4.2. AP – ADVANCED SETTINGS

PAR.	DESCRIPTION	VALUES	STANDARD
AP01	Pump suction pressure (psi)	-9÷45 (VS Series 17080V037C-2) -6÷30 (VS Series 17080V022C-1)	0
AP02	Reset to factory set-up	No, Yes	No
AP03	Low Power operating Time Threshold	0÷240 (minutes)	0
AP04	Safe-start mode activation time	1÷30 (minutes)	0
AP05	System dynamics	0 Standard 1 Slow 2 Fast	0
AP06	Pressure drop allowed to consider all taps closed (psi)	2÷72	4
AP07	Adjusting the switch off attempt	5÷30 (VS Series 17080V037C-2) 3÷52 (VS Series 17080V022C-1)	18 (VS Series 17080V037C-2) 12 (VS Series 17080V022C-1)
AP08	Switching On/ Off Bluetooth communication	0,1	1

#### 7.4.3. GP – BOOSTER SETS SETTINGS

PAR.	DESCRIPTION	VALUES	STANDARD
GP01	Mode	0 = single pump 1 = booster set with random starts	0

#### 7.4.4. BOOSTER SET WITH RANDOM STARTS

To activate the mode booster set with random starts (which consists of the single pump behavior with the addition of a random delay both when the pump is turned on and off) follow the procedure.

1. Operation to be performed for each pump:

1.1 Turn on the pump and set it to STOP.

1.2 Access the GP menu.

1.3 Set GP01=1.

The settings of the stop pressure and restart pressure remain enabled by parameters UP01 and UP02 as for normal single pump mode.

For correct booster set mode operation UP01 must be the same for both pumps, also UP02 must be the same for both pumps. Booster set mode provides a random delay in switching on (0-5s) and a random delay with respect to the timing of the switch-off attempt (0-10s).

#### 7.5. OPERATING MODES

The operating mode allows you to keep the system pressure constant at a setpoint value adjustable with the UP01 parameter. The restart pressure can be calculated by subtracting UP01 – UP02, the latter defined as pressure hysteresis. The product is equipped with a membrane that works as an expansion vessel. The AP06 parameter is the pressure drop at which all taps are considered closed and so the pump is switched off. The AP07 parameter allows you to adjust the switch off attempt.

### 7.5.1. WARNING FOR HIGH NUMBER OF STARTS/HOUR

The TANK symbol will light up, due to a warning for a high number of starts and stops, if the pump achieves at least 20 starts in a short time (cycle time less than 5 seconds).

Press (enter) to reset the warning.

If the pump starts more than 150 times in 1 hour, Er05 will be displayed.

### 7.5.2. DRY-RUN SETTINGS MANAGEMENT

In case of pump not primed and without water inside the pump casing:

UP03=0 (default)

In normal operating conditions, i.e. after the first start (15s), the warning Er01 is displayed so the pump will try to start again every 10 minutes for 5 seconds for maximum 5 times. In the case that all these attempts fail, Er01 is kept displayed until the error is reset or the pump is switched off and back on again.

UP03=1

Alternative management, i.e. after the first attempt (15s), Er01 is displayed and the pump will try to start again every 10 minutes for 5 seconds, after that the pump will try to start again every 24h for 5s (there is no limit of attempts in this case). However, it is still possible to manually reset or restart the pump. Obviously, manual reset is possible even by switching the pump off and back on.

In case of pump not primed with water inside the pump casing. The first priming attempt lasts 120s and the next ones last for 30s for maximum 5 times.

If UP03=1 the attempts continue every 24h lasting 30s.

### 7.5.3. FORCED START

To avoid any mechanical blocks, if the pump is on stand-by for more than 24 hours, the pump starts running for a minimum time of 5 seconds, and then until the stop pressure UP01 has been reached. A forced start does not take place if the pump has been manually turned OFF.

### 7.5.4. FORCED STOP

By means of the parameter AP03 it is possible to set a timer that forces the pump to stop if it works in lower power consumption conditions. In this way it is possible to prevent the pump from not stopping when there is no water demand from the final users.

AP03 is disabled by default but values from 0 to 240 minutes can be entered.

### 7.5.5. ENABLING SAFE-START

The safe-start function can be enabled. This function prevents pressure peaks in the pipework. The Safestart function is triggered whenever the power-supply is cut off.

To enable this function, it is necessary to set the parameter AP04 with a value other than zero (default).

At every interruption of the voltage supply, when the voltage supply is restored, the pressure value will reach 70% of the set-point value (UP01) for a time defined by the parameter

- a) AP04. After that time the pressure reaches the set-point value
- b) as in normal mode.

### 7.5.6. OPERATION WITH EXTERNAL TANK

We recommend installing an external tank of maximum 2 gallons when:

- The pump works for prolonged periods at low flow rates (0,5GPM or less), see paragraph. 8.6.
- Er05 or the TANK symbol appears

c) For systems with external membrane tank it is recommended to set AP05 = 1.

If pressure fluctuations are detected in the system (intermittent operation) it is necessary to set AP05 = 1.

An expansion tank is required in any system connected to a hot water heater to accommodate the thermal expansion of water. Many systems may already include an expansion tank. For those that do not, we recommend the following tanks, which are suitable for most installations:

For VS Series 1 HP: AY's 2-gallon tank (Model 16002-V3M)  
For VS Series 2 HP: AY's 5-gallon tank (Model 16005-V3M)

The tank should be installed between the pump discharge and the water heater, or on the cold-water supply line to the heater.

The appropriate tank size and precharge pressure depend on the water heater's capacity and temperature setting. For detailed guidance, please consult the water heater manufacturer or contact Baker Water Systems directly.

### 7.6. PASSWORD ENTRY

To enter a menu with a password, four digits appear on the display, and the number to enter is blinking.

The factory password is 1959.

By pushing buttons + (plus) or - (minus) you can change the blinking value. If you confirm with (enter) the following number starts blinking. If the password is correct, you can enter the menu; if the password is incorrect, the first number will start blinking again.

To exit the program, push MENU until you arrive on the parameter page. When you exit programming mode, the icon disappears.

### 8. START-UP AND OPERATION

#### 8.1. PRELIMINARY CHECKS BEFORE START-UP

Do not start-up the device in case of damaged parts.

#### 8.2. PARAMETERS TO BE SET AT THE START-UP

The electric pump is already set with all the operating parameters, therefore it is not necessary to modify any parameters for operation.

**ATTENTION:** at the first start-up check that with all the taps closed the system stops. If the pump does not stop change the stop pressure (UP01) according to the system needs, check that there are no suction leaks and check that there is no air inside the pipes.

#### 8.3. INCOMING PRESSURE SETUP

VS Series has a preset incoming pressure equal to 12 PSI. This allows the user to increase the pressure up to 80 psi. If the water comes from a tank, well, or pond, the incoming pressure should be adjusted for optimal performance. To set the incoming pressure parameter, AP01 must be changed. For proper operation, a suitable incoming pressure value should be used (negative if operating with suction lift, positive if with positive suction head).

The maximum recommended pressure by code is 80 PSI; however, if VS Series is used in an application that requires a pressure above 80 PSI, please contact our customer service. **ATTENTION:** After modifying parameter AP01, it is essential to adjust parameters UP01 and UP02 to ensure they are suitable for the application and to ensure the system starts and stops correctly. During programming, the product will suggest initial values for these parameters.

**ATTENTION:** The maximum values set in parameter AP01 must not exceed the product's maximum allowable pressure.

#### 8.4. FIRST START-UP



**ATTENTION:** never run the pump dry. Start the pump after filling it completely with water and after adjusting the membrane pressure (chap. 8.6). When the pump is located above the water level (suction lift operation chap. 14 fig. 2) or with a positive suction head which is too low (less than 3,3 ft) to open the check valve, fill the pump through the priming hole (chap. 14 fig. 4).

**ATTENTION:** the pump is equipped with a check valve built into the pump suction, in order to fill the suction pipe it is necessary to prepare a filling system on the suction pipe (chap.14 fig.4). When the water level on the suction side is above the pump (inflow under positive suction head chap. 14 fig. 1), fill the pump by opening the suction gate valve slowly and completely, keeping the delivery gate valve open to release the air.

Before starting, check that the shaft turns by hand. For this purpose use the screwdriver notch on the shaft end on the ventilation side.

#### 8.5. SELF-PRIMING

(Capability to clear the air in the suction pipe when starting with the pump located above the water level).

Conditions for self-priming:

- Suction pipe with connections perfectly airtight and properly immersed in the water to be lifted;
- Allow 2 ft minimum of straight vertical pipe above the discharge port, before a check valve or a bend chap.14 fig. 4.
- Pump casing completely filled with clean cold water before start-up.

The pump is not self-priming with water containing oil, alcohol or foaming substances. The integrated check valve prevents reverse siphoning through the pump when the pump is stopped and retains water in the pump for the next start-up.



**ATTENTION:** avoid prolonged operation with the pump not primed, without water delivery from the completely opened outlet. If the pump does not prime in 5 mins:

stop the motor, remove the filler cap and add more water. If necessary, repeat the priming operation after the pump has been first emptied and then completely filled with clean cold water.



**ATTENTION:** When self-priming for the first time, once the pump has been primed, it may be necessary to stop the pump, wait a few seconds and then restart it with all taps opened, in order to eliminate the air inside the pump asing completely.

During the self-priming time, if the pump does not prime within 2 minutes (5 minutes for VS Series 17080V022C-1), Er07 “not primed” appears. Press the enter button for the reset and the start button to restart the pump.

#### 8.6. VESSEL PRESSURE

Once the new re-start pressure is entered (parameter UP01-UP02), the membrane pre-charge pressure must be changed to 7.25 psi lower than the re-start pressure (i.e. 42 psi re-start pressure, membrane at 34.8 psi) par. 14 chap. 6.

**ATTENTION:** Do not pre-inflate the tank membrane over 50.7 psi; if a higher pressure is required, install an external tank. If the pump works for long periods of time with a flow rate of

0,5 GPM or lower it is necessary to install a tank of maximum 2 gallons.

#### 8.7. GATE VALVE ADJUSTMENT

With the gate valve completely open or with an outlet pressure lower than the minimum pressure shown on the nameplate, the pump may be noisy. To reduce noise adjust the delivery gate valve.

#### 8.8. ABNORMAL OPERATION



Never run the pump for more than five minutes with a closed gate valve.

Prolonged operation without a change of water in the pump causes dangerous increases of temperature and pressure. Prolonged operation with a closed delivery port causes breakage or damage to parts of the pump. When the water is overheated due to prolonged operation with a closed port, stop the pump before opening the gate valve. Do not touch the fluid when its temperature is higher than 140 °F. Do not touch the pump when the surface temperature is higher than 176°F. Wait until the water has cooled inside the pump before starting again or opening the draining and filling plugs.

#### 8.9. SWITCH-OFF



The appliance must be switched off every time there are faults. (see troubleshooting).

The product is designed for continuous operation, the switch off is performed by disconnecting the power supply by means of the dedicated disconnecting devices. (see paragraph “6.5 Electrical connection”).

#### 9. MAINTENANCE

Before any operations it is necessary to disconnect the power supply. If required ask an electrician or an expert technician.



All maintenance operations, cleaning or repairs performed with the electrical system connected could cause serious injuries to people.



If the power cable is damaged, it must be replaced by the manufacturer, its service agent or similarly qualified persons in order to avoid a hazard.

In case of extraordinary maintenance, or maintenance operations that require removing parts, the operator must be a qualified technician able to read diagrams and drawings. It is advisable to keep a record of all maintenance operations performed.



During maintenance, be very careful not to allow foreign bodies to enter the circuit, even if very small, as the safety of the device could be compromised.



It is forbidden to perform any operations using your bare hands. Use water-resistant, anti-cut gloves to disassemble and clean the filter or in other particular cases.



During maintenance operations external personnel is not allowed.

Maintenance operations that are not described in this manual must be performed only by specialized personnel authorized by the manufacturer.

For further technical information regarding the use or the maintenance of the device, contact the manufacturer.

### 9.1. ROUTINE MAINTENANCE



Before all maintenance operations disconnect the power supply and make sure that the device cannot be accidentally connected.



If possible, as in the case of temporary operation with dirty liquids, run the pump briefly with clean water to remove deposits.

When the pump remains inactive it must be emptied completely if there is a risk of freezing (chap.14 fig. 5).

Before restarting the pump, check that the shaft is not jammed and fill the pump casing completely with clean water.

### 9.2. VESSEL MAINTENANCE

Periodically check the pre-charge pressure of the membrane inside the pump (chap. 14 fig. 6)

### 9.3. DISMANTLING THE SYSTEM

Close the suction and delivery gate valves and drain the pump casing before dismantling the pump.

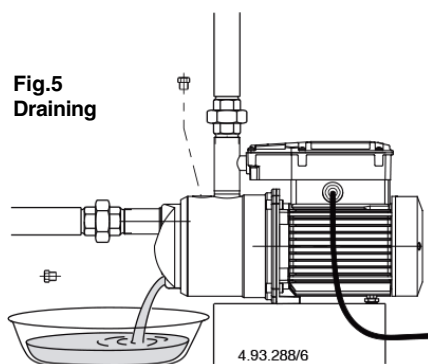

### 9.4. DISMANTLING THE PUMP



Close the suction and delivery gate valves and drain the pump casing before dismantling the pump (chap. 14 fig. 5).

### 10. DISPOSAL



The final disposal of the device must be entrusted to a company specialized in the disposal of scrap metal, so that they can carefully define how to proceed.

For disposal, comply with the laws in force in the Country where the device is dismantled, as well as the international laws for the protection of the environment.

### 11. PARTS BREAKDOWN

14.00 Pump casing	70.00 Lantern bracket
14.04 Plug	73.00 Ball bearing
14.06 O-ring	76.00 Motor casing with winding
14.12 Plug	76.06 Nut
14.16 O-ring	76.16 Support
14.20 O-ring	78.00 Shaft with rotor packet
14.24 Screw	81.00 Ball bearing
14.47 O-ring	82.00 Motor end shield
14.64 Valve, set	82.02 Screw
14.66 Retaining ring	82.04 Compensating spring
16.00 Suction casing	82.08 Screw
16.02 Suction casing adapter	88.00 Motor fan
16.14 Plunger	90.00 Fan cover
16.15 Spring	90.04 Screw
16.16 O-ring	92.00 Tie-bolt
16.17 Valve	96.02 Cable with plug
17.00 Membrane	98.00 Terminal box cover
17.04 Valve casing	98.04 Screw
17.06 Nut	98.08 Gasket
17.08 Valve casing plug	98.20 Screw
17.10 Tank cover	98.51 Transducer
17.20 Membrane cap	98.52 Signals cable
22.12 O-ring	98.54 Display cable
22.16 O-ring	98.55 Terminal box cover / board
25.01 First stage casing	98.56 Transducer stop fork
25.02 Stage casing (complete)	98.57 Transducer connection fitting
25.05 Last stage casing)	98.58 Transducer connection o-ring
25.07 Last stage casing adapter	98.60 Control board + Input signal board
28.00 Impeller	98.63 Power board
28.04 Impeller nut	98.64 Control card / input / power signals
28.08 Washer	98.70 Screw
34.00 Casing cover	98.71 Screw
36.00 Mechanical seal	98.72 Shoulder washer
36.51 Retaining ring, split	98.74 Thermal pad
36.52 Shoulder ring	98.75 Thermal pad
36.54 Spacer sleeve	
46.00 Deflector	
64.13 Spacer sleeve	
64.15 Spacer sleeve	

12. ALARMS





Error reset can be automatic or manual, depending on the error that occurs. Manual reset is carried out using the enter button and then start to restart the pump.

CODE	DESCRIPTION	RESET ERR	CAUSE	SOLUTION
Er01	Fault due to absence of water. Absence of water in the pump body	MAN	a) Absence of water in the pump-body, pos. 14.00	a1) Check that the pump body, pos. 14.00 is filled with water by opening the filler cap pos.14.04 and top up with water until it is completely filled. a2)If the water level inside the pump body, pos. 14.00, completely filled should continue to fall, check the tightness of the complete valve pos. 14.64 by removing the suction pipe from the pump body, pos. 14.00 and check that the shutter of the valve itself closes the water passage correctly. If necessary, remove any foreign bodies between the valve body and the shutter. If the problem persists, contact an authorized service center.
Er02	Faulty pressure sensor	MAN	Pressure sensor breakage	Contact an authorized service center
Er03	Fault due to low supply voltage	AUT	Low line voltage, less than 185V (VS Series 17080V037C-2) o 85V (VS Series 17080V022C-1). It is restored when there is a voltage at the terminal greater than 190V (VS Series 17080V037C-2) o 90V (VS Series 17080V022C-1).	- Read the voltage on the display and check the line voltage. If the two values are consistent and below the 185V (VS Series 17080V037C-2) o 85V (VS Series 17080V022C-1) threshold, adjust the power supply line, using a cable with a larger section and/ or provide a shorter line. - Contact the operator to check the quality of the power supply being used - If the problem persists, contact an authorized service center.
Er04	Fault due to high supply voltage	AUT	High line voltage, greater than 260V. It is restored when there is a voltage at the terminal of less than 255V.	- Read the voltage on the display and check the line voltage. - Contact the operator to check the quality of the power supply being used.
Er05	Fault due to number of starts exceeded	MAN	The system has performed more than 150 starts/hour due to: a) Incorrect setting of the parameters b) Loss of pressure. The electric pump attempts to restart after 5 minutes for a total of 6 attempts.	a1)Check the correct setting of the parameters according to the type of system (in intake or positive suction head). If necessary, reset the previously set settings (follow the programming guide instructions, para. 7). a2)Follow the procedure for First Power On b1)Check that, once the shut-off valve on the delivery side is closed, the electric pump does not start cycling again. If the electric pump does not restart, this means that there are pressure drops in the system delivery. b2)Once the shut-off valve on the delivery side has been closed, if the electric pump continues to cycle, the check valve pos. 14.64 may not close the water passage properly. If necessary, remove any foreign bodies between the valve body and the shutter. If the problem persists, contact an authorized service center.
Er06	Fault due to overcurrent in the electric pump motor	MAN	The rotation of the motor shaft is blocked. The electric pump makes a restart attempt every 10 seconds for a total of 3 attempts.	Try to unlock the shaft with a flat screwdriver using the dedicated notch on the shaft visible in the rear part of the electric pump through the cap pos. 90.00 If the problem persists, contact an authorized service center.
Er07	Pump not fully primed	MAN	The electric pump is installed in intake with the pump body completely filled. The system is set to attempt a restart every 10 minutes for a total of 5 attempts. a) Suction height greater than 13 ft (VS Series 17080V037C-2) or 9.8 ft (VS Series 17080V022C-1) b) Suction pipe with pressure drop higher than 13 ft (VS Series 17080V037C-2) or 9.8 ft (VS Series 17080V022C-1) c) Suction pipe not completely immersed in water d) Pipe not completely sealed e) Valve of pos. 14.64 blocked in closing position f) Insufficient water flow in the suction pipe g) Suction pipe with too large a volume h) Lack of water in the suction tank: the unit stops and then restarts automatically, attempting a restart every 10 minutes for a total of 5 attempts.	Open the filler cap pos.14.04 and check complete filling of the pump body pos. 14.00, top up if necessary and check the seal of the check valve pos. 14.64 making sure that the water level in the pump body remains constant. a) Pump not suitable for the application. b) Increase the diameter of the suction pipe. c) Check the correct positioning and length of the suction pipe. d) Check that there are no air intakes by tightening the joints and check that the pipe is intact. e) Disassemble the suction pipe and check the correct movement of the shutter of the check valve, pos. 14.64. f) Check that the suction pipe is not clogged and that the section of the pipe is not less than 1". g) Pipe too long and/or diameter too large. h) Restore and guarantee the correct suction water level. Install an electric float in the suction tank which interrupts the operation of the pump below the safety level (0.5m above the axis of the suction pipe).

CODE	DESCRIPTION	RESET ERR	CAUSE	SOLUTION
Er08	Fault due to internal overtemperature	AUT	Electronic board overtemperature detected. The error resets automatically when the temperature drops. a) Ambient temperature too high b) Excessive irradiation. c) For VS Series 17080V037C-2, insufficient ventilation. d) Board problem	a) Pump not suitable for the application. b) Prepare a guard from radiation around the electric pump. c) Check the spaces around the electric pump, check that the fan rotates integrally with the shaft (for VS Series 17080V037C-2). d) If the problem persists, contact an authorized service center.
Er09	Overpressure Fault	MAN	Pressure over 120 psi. a) Suction pressure too high b) Water hammer c) Delivery pressure above the limit, caused by another system pressure booster.	a) The maximum inlet pressure is greater than the maximum value AP01, insert a pressure reducer on the inlet. b) Avoid abrupt closing maneuvers (e.g. avoid quick-closing solenoid valves on delivery). Fit a check valve on the delivery side. c) Check the correct seal of the delivery check valve (if not present, install one).
Er10	Intervention of the thermal protector detected	MAN	Motor overheating	Contact an authorized service center.
Er11	Fault due to air presence	MAN	With the pump body full of water and the pump fully primed, the UP01 set point is not reached despite working at maximum rotation speed; the flow rate is insufficient. a) Interruption of the continuity of the suction water flow. b) Excessive intake turbulence.	a) Install an electric float in the suction tank that stops the pump from working below the safety level (1.64 ft above the axis of the suction pipe). b) Avoid return flows with rain falls or recirculations that could disturb the incoming flow.
Er30	Current imbalances	MAN	The pump works without the AP01 parameter having been adequately set.	Set the correct value of AP01 and set AP05=1
From Er26 to Er29 and Er31	Internal hardware error	MAN		Contact an authorized service center

### 13. WARNING

The Warning remains active until the cause is no longer present. In the Warning condition, the pump can still operate normally but it may be near the limits of the Error condition.

CODE	SYMBOL	CAUSE	SOLUTIONS
W1		20 restarts with stand-by time less than 5s.	Check the membrane pressure, if necessary install a tank of maximum 5 gallons.
W2		The pump is not properly primed or there is air inside the pump casing. The pump restarts whenever the system pressure is under the restart pressure threshold.	Make sure that the pump casing is full of liquid and that all the air has been expelled.
W3		20 restarts with pump RUN time less than 30s.	Check if there are small leaks in the system.
W4		The pump is running on the left part of the performance curve.	No action required, the display provides this information to indicate low consumption such as one utility open or several utilities open in partial mode.
W5		The pump is running on the right part of the performance curve.	The pump is working with a low back pressure: 1) The hydraulics may be clogged and therefore require maintenance 2) The electric pump is undersized with respect to how it is used and it is necessary to use a unit capable of supplying a higher flow rate.

## 14. TROUBLESHOOTING

**WARNING:** Turn off the power supply before performing any operations. Do not allow the pump or motor to run when dry even for a short period. Strictly follow the user instructions and if necessary contact an authorized service center.

PROBLEM	PROBABLE CAUSE	SOLUTIONS
The motor does not start	<ul style="list-style-type: none"> <li>- Unsuitable power supply.</li> <li>- Shaft blocked.</li> <li>- If the above causes have already been checked, the motor may be malfunctioning.</li> </ul>	<ul style="list-style-type: none"> <li>- Check that the main's frequency and voltage correspond to the electrical characteristics shown on the plate.</li> <li>- Remove the cause of blockage as indicated in the "Blocked pump" instruction booklet.</li> <li>- Repair or replace the motor by contacting an authorized service center.</li> </ul>
Pump blocked	<ul style="list-style-type: none"> <li>- Prolonged periods of inactivity with formation of rust inside the pump.</li> <li>- Presence of solid bodies in the pump impeller.</li> <li>- Bearings seized.</li> </ul>	<ul style="list-style-type: none"> <li>- Unblock the pump by using a screw driver to turn the relevant notch on the back of the shaft (remember to turn off the electricity supply first ) or contact an authorized service center.</li> <li>- If possible, dismantle the pump casing and remove any solid foreign bodies inside the impeller, if necessary contact an authorized service center.</li> <li>- If the bearings are damaged replace them or if necessary contact an authorized service center.</li> </ul>
The pump works but no water comes out	<ul style="list-style-type: none"> <li>- Possible infiltration of air from suction tube connections, drain plugs or filling of pump or from the gaskets of the suction pipe.</li> <li>- Foot valve blocked or suction pipe not fully immersed in liquid.</li> <li>- Suction filter blocked.</li> <li>- Check valve blocked.</li> </ul>	<ul style="list-style-type: none"> <li>- Check which part is not tight and seal the connection adequately</li> <li>- Clean or replace the bottom valve and use a suction pipe suitable for the application</li> <li>- Clean the filter, if necessary, replace it . See point 2a) also.</li> <li>- Verify that the integrated check valve is working properly.</li> </ul>
The pump does not stop	<ul style="list-style-type: none"> <li>- Check valve broken, blocked or clogged with solid parts.</li> <li>- Stop pressure (parameter UP01) too high.</li> <li>- Insufficient pump performance.</li> <li>- Incorrect membrane pressure, empty or broken membrane.</li> </ul>	<ul style="list-style-type: none"> <li>- Check the operation of the integrated check valve and remove the solid parts present in the valve.</li> <li>- Check the value of parameter UP01 and if necessary reduce it.</li> <li>- Contact an authorized service center.</li> <li>- Check the membrane pressure, if necessary install a tank of maximum 5 gallons.</li> </ul>
Intermittent operation	<ul style="list-style-type: none"> <li>- Resonances between pump and hydraulic system control dynamics</li> </ul>	<ul style="list-style-type: none"> <li>- Set AP05 = 1</li> </ul>
Insufficient flow	<ul style="list-style-type: none"> <li>- Pipes and accessories with diameter too small causing excessive loss of head.</li> <li>- Presence of deposits or solid bodies in the internal passages of the impeller.</li> <li>- Impeller deteriorated.</li> <li>- Worn impeller and pump casing.</li> <li>- Excessive viscosity of the water pumped.</li> <li>- Suction head excessive in relation to the suction capacity of the pump.</li> <li>- Suction pipe too long.</li> </ul>	<ul style="list-style-type: none"> <li>- Use pipes and accessories suitable for the specific application.</li> <li>- Clean the impeller and install a suction filter to prevent other foreign bodies from entering.</li> <li>- Replace the impeller, if necessary, contact an authorized service center</li> <li>- Replace the impeller and the pump casing.</li> <li>- The pump is unsuitable.</li> <li>- Try to close the delivery gate valve partially and/or reduce the difference in level of the pump and the water being sucked.</li> <li>- Bring the pump closer to the suction tank so as to use a shorter pipe. If necessary use a pipe of a wider diameter.</li> </ul>
Noise and vibrations from the pump	<ul style="list-style-type: none"> <li>- Rotating part unbalanced.</li> <li>- Worn bearings.</li> <li>- Pump and pipes not firmly attached.</li> <li>- Flow too strong for the diameter of the delivery pipe.</li> <li>- Operation in cavitation.</li> <li>- Unbalanced power supply.</li> </ul>	<ul style="list-style-type: none"> <li>- Check that no solid bodies are obstructing the impeller.</li> <li>- Replace the bearings.</li> <li>- Anchor the delivery and suction piping as needed.</li> <li>- Use bigger diameters or reduce the pump flow.</li> <li>- Reduce the flow by adjusting the delivery gate valve and/or using pipes with a bigger internal diameter. See point 6g) too.</li> <li>- Check that the main's voltage is suitable.</li> </ul>
Leakage from the mechanical seal	<ul style="list-style-type: none"> <li>- The mechanical seal has operated when dry or has stuck.</li> <li>- Mechanical seal scored by presence of abrasive parts in the water pumped.</li> <li>- Mechanical seal unsuitable for the type of application.</li> <li>- Slight initial drip during filling or on first start-up.</li> </ul>	<ul style="list-style-type: none"> <li>- In cases 8a), 8b) and 8c), replace the seal, if necessary contact an authorized service center</li> <li>- Make sure that the pump casing (and the suction pipe if the pump is not self-priming) are full of liquid and that all the air has been expelled. See point 6e) too.</li> <li>- Install a suction filter and use a seal suitable for the characteristics of the liquid being pumped.</li> <li>- Choose a seal with characteristics suitable for the specific application</li> <li>- Wait for the seal to adjust to the rotation of the shaft. If the problem persists, see points 8a), 8b) or 8c) or contact an authorized service center.</li> </ul>