

# Haight Pumps . . . For Superior Performance

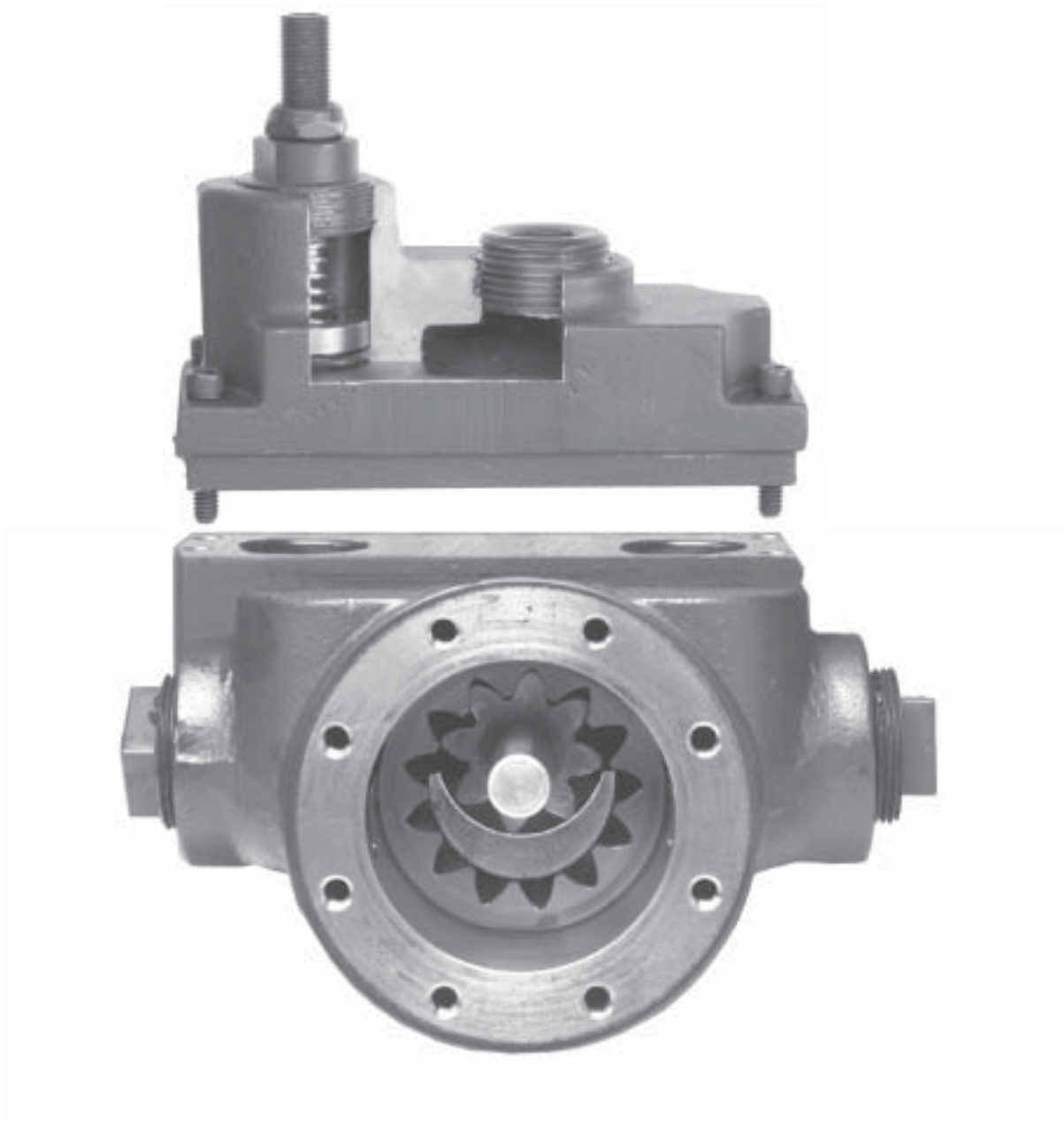

## Operating, Maintenance, and Instruction Manual

# Operating Manual for Haight Positive Displacement Rotary Gear Pumps

## Pre-Installation

1. Choose a location that is easily accessible for pump servicing. Ensure adequate electrical service is available.
2. Locate the pump for direct piping. Special attention should be given to the suction piping which should be as large, or larger, than the pump intake port. **For efficient operation, it is essential the suction side of a gear pump not be restricted.** Avoid tees, elbows, valves, and other flow devices within 12 pipe diameters of the pipe inlet. Provide adequate support for the piping. The pump should not be used to support piping.
3. Pumps are shipped with the suction port marked - **IN**; the discharge port marked - **OUT**. The suction port on pumps with relief valves is the port nearest to the relief valve adjusting screw.
4. Pumps will operate in either direction. However, the relief valve will only function in one direction. Relief valve components are symmetrical and can be installed to operate with either clockwise or counter-clockwise shaft rotation.
5. Have an electrician connect the motor using sound practice. Provide adequate overload protection. **Note: When checking the direction of rotation, the pump must be full of liquid. Pumps fitted with mechanical seals must not run dry, not even momentarily.** Determine the direction of rotation by watching the motor fan.
6. The motor selected meets the requirements of the specified operating conditions. Changed conditions, for example, higher viscosity, higher specific gravity, or lower head losses, can overload the motor. When changing operating conditions, or whenever there is any doubt, please contact your local distributor with the full details.

## Installation

1. Provide a solid foundation free from excessive vibration.
2. Shim to prevent distortion of the pump mount base. Securely anchor the pump and motor to the foundation.
3. All pipe connections on the suction side of the pump must be air tight. An air leak on the suction side of the pump will result in the loss of prime.
4. Provide priming tee on the discharge line of the pump.
5. If the media pumped contains solids, a suction strainer is recommended to exclude solid particles from the pump. Contact Haight Pump for a recommendation.
6. Support the piping independent of the pump. Excessive strain on the pump casing can interfere with gear alignment.
7. When the piping is complete, loosen the bracket set screws and allow the pump to align with the piping. Tighten the bracket set screws and re-check the shaft alignment. Make sure there is no metal to metal contact of the coupling halves. Do not over tighten the pipe/pump connections, as damage can result.
8. A vacuum gauge can be installed in the pipe plug on the relief valve nearest the adjustment screw. A pressure gauge can be installed in the opposite pipe plug.
9. Check the shaft rotation to ensure it is correct. Normal rotation is clockwise as viewed from the shaft side of the pump.

### **Precautionary Notes**

1. Prior to performing any service on the pump or motor:
  - (a) Disconnect and lockout the power source to the motor (refer to OSHA 1910.147.)
  - (b) Shut off any liquid heating source.
  - (c) If the unit operates at elevated temperatures, allow it to cool to room temperature before performing any service.
2. Drain the pump and piping of excess liquid. *Caution: Handle and dispose of liquids in accordance to the manufacturers Material Safety Data Sheets.*

### **Disassembly for Inspection Purposes Only**

1. Remove the bolts from the drive plate.
2. Carefully separate the drive cover and housing. Rotate the pump shaft by hand. It should turn freely. If resistance is present, check for built up residue.
3. Use a soft marker to mark the rotor/pinion location. Remove the rotor from the housing.
4. Inspect the housing, shaft/pinion, rotor, and drive plate for signs of wear or damage. Excessive wear will decrease pump performance.
5. Inspect the O-rings, gaskets, and bearings for chipping, splitting, or missing sections.
6. Inspection of the pump seal requires complete removal of the pump from the motor and bracket.

### **Complete Disassembly for Repair or Replacement**

1. Complete precautionary steps 1 and 2.
2. Loosen the support bracket screws that secure the pump to the bracket.
  - (a) Size 1-8 pumps: 3 set screws
  - (b) Size 10-80 pumps: 4 cap screws
3. Remove the coupling and shaft key. Inspect the shaft end for burrs or other damage.
4. Rotate the pump shaft by hand. It should rotate freely.
5. Remove the bolts from the drive plate.
6. Carefully separate the drive cover and housing.
7. Use a soft marker to mark the rotor/pinion location. Remove the rotor from the housing.
8. Remove the shaft/pinion assembly from the housing.
9. Carefully pry the cover off the housing.
10. Inspect, repair, or replace all damaged parts. *Note: If significant damage is evident to the major pump components, it is best to replace the pump.* If possible, determine the cause of the damage and correct the identified problem.

## **Reassembly**

1. Pump reassembly is the reverse of disassembly. However, care should be exercised in three areas:
  - (a) It is good practice to replace elastomer sealing devices and gaskets every time the pump is reassembled. This is mandatory for Teflon O-rings and lip seals. Gently stretch the O-rings before placing them in the O-ring groove.
  - (b) Place the rotor into position with your mark facing out.
  - (c) Use a cross bolt tightening pattern to re-assemble the housing and covers. Periodically turn the pump shaft. Check for unusual noise. Improper tightening will cause the pump to bind.
2. The pump will function best if primed first. Return the pump to service and check for leaking and loose connections. Air leaks on the suction side of the pump will reduce pump performance.

## **Relief Valve Components**

1. See precautionary notes.
2. To change the relief valve for reverse rotation:
  - (a) Loosen the locknut on the adjusting screw while holding the adjusting screw stationary.
  - (b) Remove the bonnet and bonnet washer.
  - (c) Remove the adjusting screw, spring, and poppet.
  - (d) Remove the cap and cap washer.
3. Reassemble in reverse order. Remember the spring and adjusting screw must be on the suction side of the pump for the relief valve to operate.

## **Special Seal Components**

1. Standard 1 through 40 D/DR pumps use a lip seal as the main shaft seal, and two wiper seals function to keep the bearings clean. These seals are available in Buna-N or Viton synthetic materials.
2. Packed pumps use 4 or 5 element V-cup Teflon shaft seals. Shaft seals are also available in Graphite rope, Graphfoil, and virgin Teflon. A gland is included to provide tension for the packing.
3. Crane Type 9 and Type 21 mechanical seals are available. Contact Haight Pump for special drawings for pumps with mechanical seals.

## **Maintenance Parts or Factory Repair**

1. When ordering parts, locate the pump serial number stamped on the machined face of the cover or body of the pump housing.
2. Haight Pump maintains a repair service shop that will rebuild, test, and return pumps promptly.
3. Remove pipes, coupling, and mounting bracket before returning the pump to the factory.
4. Contact Haight Pump for a Return Authorization number before sending the pump to the factory.

## **General Information**

The following is general information about Haight rotary gear pumps. Due to the variety of options and configurations available, it is not possible to provide detailed information in this manual. Detailed drawings and bill of materials will be provided upon request.

***Never operate a pump with the discharge line closed or plugged. Severe damage to the pump and/or system will result.***

***Haight Pump does not accept responsibility or liability for damage or injury resulting from improper application and/or operation of the pump and/or system.***

Direction of Rotation. Haight pumps are designed to operate in either direction by simply changing the shaft rotation. Pumps supplied with relief valves are the exception to this rule. Failure to reverse the relief valve components will render the relief valve inoperable. The procedure for reversing the flow direction in the relief valve is covered in the *Assembly and Disassembly* instructions.

Pump Alignment. Bedplate mounted pumps and motor combinations are aligned and tested at the factory. Vibration during shipment and/or poor bedplate mounting conditions can cause premature failure or unacceptable noise and vibration.

Simple alignment checks can be performed by placing a straight edge on the top and side of the coupling. Improper alignment is indicated by a separation between the coupling and straight edge. Adjust the motor and pump location until any separation disappears in both planes.

Bedplate Mounting. Install nuts on the foundation bolts to provide location adjustment. Loosely place the bedplate on the foundation bolts. Adjust the bedplate height and location to meet the inlet and outlet piping. Ensure the bedplate is level and true. Fasten in place with lock washers or lock nuts. Check coupling alignment.

Piping. Improper suction piping is the leading cause of poor pump performance, including cavitation, noisy operation, inadequate performance, and premature pump failure. Particular care should be taken to avoid long, restricted pipe runs, the use of elbows, tees, valves, or other flow devices within twelve (12) pipe diameters of the pump inlet. Inlet piping should be at least equal to the pump inlet size.

The discharge piping arrangement is somewhat less critical than the inlet side, however, good engineering practice, as defined by the *Hydraulic Institute*, should be followed.

Pumps are not designed to be used as piping system support devices. Piping systems should have adequate, independent hangers to provide support. Again, the *Hydraulic Institute* offers guidelines for proper pipe support design.

Seals. Haight Pump offers three standard type seals, each with specific operating characteristics.

- *Lip seals:* Available in Buna-N, Viton, Teflon, Silicone, and Kalraz seals. Lip seals are inexpensive, but have certain limitations, which include:
  - Expected operating life of 2,000 -3,000 hours
  - Should not be used with system pressures over 75 psig
  - Should not be used in vacuum applications over 3" Hg

### **General Information: Seals (cont'd)**

- *Packing gland:* Available in Graphfoil, or Teflon, and other materials upon request. Packing glands are useful at high temperatures and pressures, resist shock and vibration, and can be adjusted to accommodate wear. However, packing glands *must weep* to function properly and require adjustment during the start-up operation.

During start-up, or after repacking, run the pump to pressurize the stuffing box. Steady weepage should occur in less than ten (10) minutes. If steady weepage has not begun within ten (10) minutes, stop the pump and allow it to cool. Overheating the gland will damage the packing gland and shaft. Do not loosen the gland adjustment screws. Repeat this process until steady weepage is established.

Adjust the packing gland screws 1/6th of a turn in a cross bolt tightening pattern. Allow to run ten (10) minutes. Continue this process until the weepage rate is approximately one (1) drop per minute. Periodic inspection and adjustment will be required. *Do not* over tighten the packing gland as damage to the gland and shaft will result.

### **Bearings and Rotor/Pinion Shaft**

*DU Bearings.* Recommended for applications over 100 PSI and for thin fluids.

*Teflon Rotor.* Do not use Teflon rotors in applications exceeding 100 PSI, and 200° F. The pump is provided with open tolerances. Increased slip will reduce efficiency with fluids below 200 SSU.

*Delrin Rotor.* Do not use above 120° F and 80 PSI. Delrin rotors provide better abrasion resistance than Teflon rotors. The pump is provided with open tolerances. Increased slip will reduce efficiency with fluids below 200 SSU.

*Stainless Steel Rotor and Pinion.* Manufactured with open tolerances as standard. Increased slip will reduce efficiency with fluids below 200 SSU.

*Note: For applications above 175 PSI, vent both shaft bearings to the suction side of pump.*

### **Spares and Repairs**

Haight Pump operates a repair service for all pumps for which records exist. To ensure the correct parts are supplied, the pump serial number is required. The serial number is stamped into the metal of the pump body or cover, in a prominent position on the top area of the pump.

We advise customers whose pumps are custom fabricated to have spare pumps or parts on hand. Custom fabricated pumps and parts generally have long delivery times for replacement.

***Pumps That Perform. Pumps That Fit.***

## **Troubleshooting**

<u>Problem</u>	<u>Probable Cause</u>
<i>No liquid delivered.</i>	<ul style="list-style-type: none"><li>• Pump not primed</li><li>• Suction lift too high; check with a gauge at the pump suction</li><li>• Wrong direction of rotation</li><li>• Pump not rotating (failure of drive from prime mover)</li></ul>
<i>Not enough liquid delivered.</i>	<ul style="list-style-type: none"><li>• Air leaks in suction line or through stuffing box</li><li>• Speed too low</li><li>• Suction lift too high, or not enough suction head (for hot liquids)</li><li>• Foot valve too small or obstructed</li><li>• Foot valve or end of suction pipe not immersed deeply enough</li><li>• Piping improperly installed, permitting air or gas to pocket in pump</li><li>• Mechanical defects:<ul style="list-style-type: none"><li>• Pump damaged</li><li>• Pump badly worn</li><li>• Packing defective</li><li>• Relief valve not sealing or jammed by foreign matter</li></ul></li></ul>
<i>Pump works for awhile, then loses suction.</i>	<ul style="list-style-type: none"><li>• Leaky suction lines</li><li>• Suction lift too high</li><li>• Air or gases in liquid</li><li>• Plugged lines or filter</li></ul>
<i>Pump takes too much power.</i>	<ul style="list-style-type: none"><li>• Speed too high</li><li>• Liquid heavier or more viscous than design condition</li><li>• Suction or discharge line obstructed</li><li>• Mechanical defects:<ul style="list-style-type: none"><li>• Shaft bent</li><li>• Rotating element binds</li><li>• Stuffing boxes too tight</li><li>• Misalignment due to improper connection of pipe lines or driver</li></ul></li><li>• Check pressure is being measured at the pump and not some distance away from the pump, thus ignoring pressure losses in piping, valves, etc.</li><li>• Poor piping conditions</li></ul>
<i>Noisy pump.</i>	<ul style="list-style-type: none"><li>• Speed too high</li><li>• Suction lift or viscosity too high (piping diameter too small)</li><li>• Wrong direction of rotation (recesses in the pump covers to prevent hydraulic noise operate only in one direction)</li><li>• Badly supported pipe or bedplates causing resonant vibration</li><li>• Relief valve chattering</li><li>• Pressure too low; an increase in pressure can prevent gear noise in low pressure applications</li><li>• Cavitation due to inlet or outlet conditions</li></ul>
<i>Gland leakage.</i>	<ul style="list-style-type: none"><li>• Packing hard and shaft scored</li><li>• Pressure on pump too high or pressure relief passage blocked</li><li>• Shaft run out excessive</li><li>• When re-packing a gland, all the old packing must be removed; it is not good enough to just add extra rings as the original packing becomes compressed</li></ul>

## 3E & 5E STANDARD "Hot Oil" PUMP REPLACEMENT PARTS

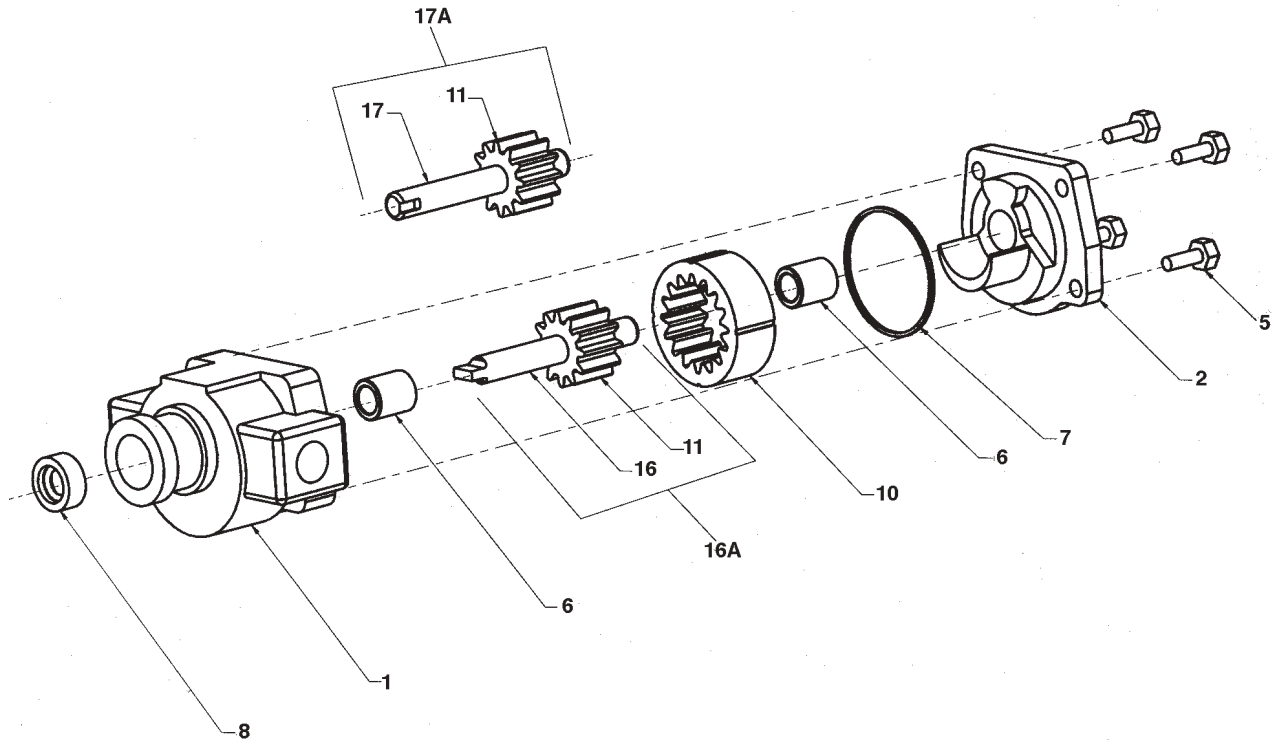

Item Number	Description	Style	Part Number	Qty Required
1	E style casing	3E & 5E	ED53F5	1
2	3E Cover	3E	ED330F	1
	5E Cover	5E	ED530F	1
5	Cover Bolts	3E & 5E	E90HC.6	4
6	Bearing	3E & 5E	E11F	2
7	Cover o-ring	3E & 5E	E28V1	1
8	Lip Seal	3E & 5E	E18V	1
10	Rotor	3E	D326F1	1
10	Rotor	5E	D526F1	1
11	Pinion	3E & 5E	N/A	1
13	Screw	3E & 5E	E46C	2
16	Shaft - Tang	3E & 5E	N/A	1
16A	Tang Shaft-Pinion Assy	3E	ED3C13BC	1
16A	Tang Shaft-Pinion Assy.	5E	RED5C13BC	1
17	Keyed Shaft	3E & 5E	N/A	1
17A	Keyed Shaft-Pinion Assy.	3E	DU3C13PK	1
17A	Keyed Shaft-Pinion Assy.	5E	DU5C13PK	1

Viton® is a registered trademark of DuPont Dow Elastomers



## 6G & 8G Hot Oil Gerotor Pump Replacement Parts

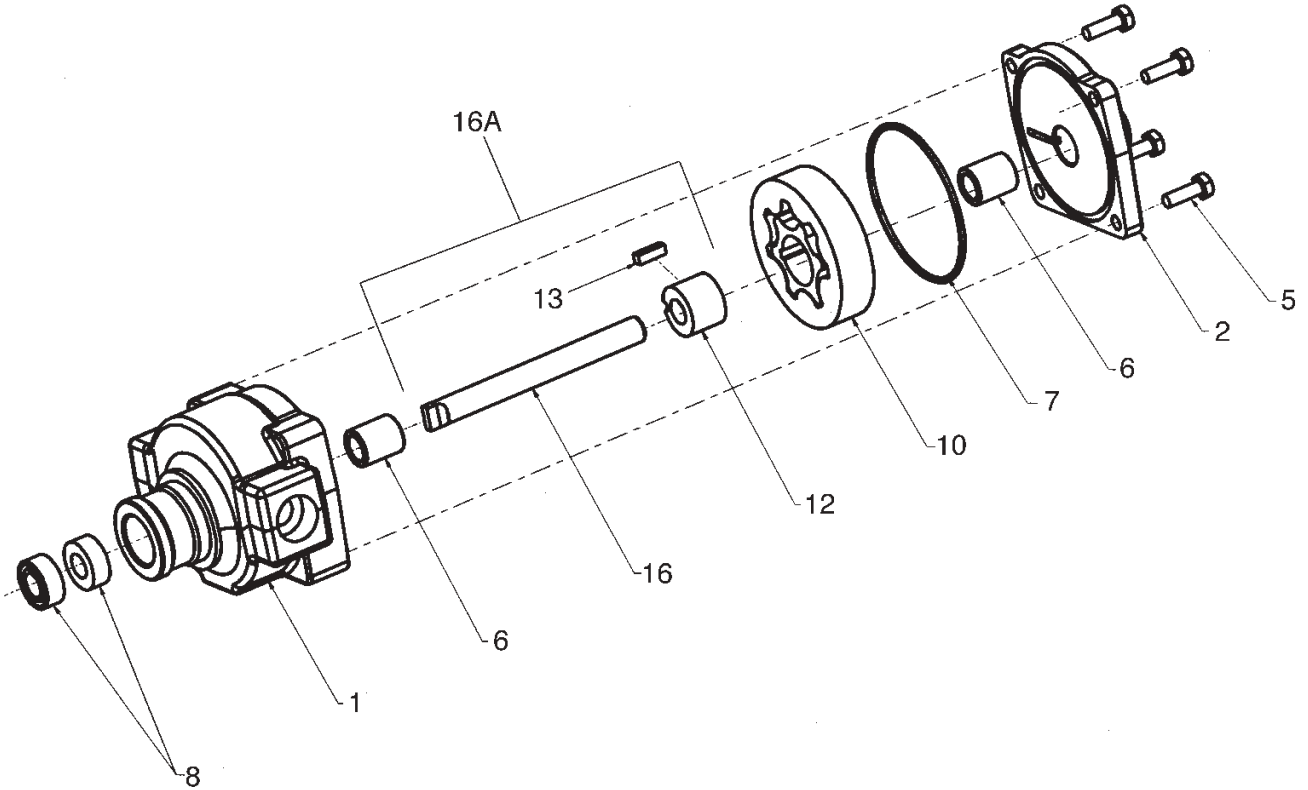

Item Number	Description	Style	Part Number	Qty Required
1	G style casing	6G	EG63F7D	1
		8G	EG83F7A	1
2	6G cover	6G & 8G	EG830F	1
5	Cover bolts	6G & 8G	E90HC.6	4
6	Bearing	6G & 8G	E11F	2
7	Cover o-ring	6G & 8G	SE2151V76	1
8	Lip Seal	6G & 8G	E18V	2
10	Gerotor Set	6G	HJ169A	1
		8G	HJ89A	1
12	Spacer	6G & 8G	HJ80A	1
13	Key	6G & 8G	F18C50	2
16	Shaft-Tang	6G	F18C50	1
		8G	ED524BC	1
16A	Shaft/Spacer/Key Assy	6G	DU6C13BC	1
16A	Tang Shaft-Pinion Assy.	8G	DU8C13BC	1
17	Keyed Shaft	8G	N/A	1
17A	Keyed Shaft-Pinion Assy.	8G	N/A	1

Viton® is a registered trademark of DuPont Dow Elastomers

# 1U through 5U Haight Pump w/o Relief Valve 1U through 5U Haight Pump with Relief Valve

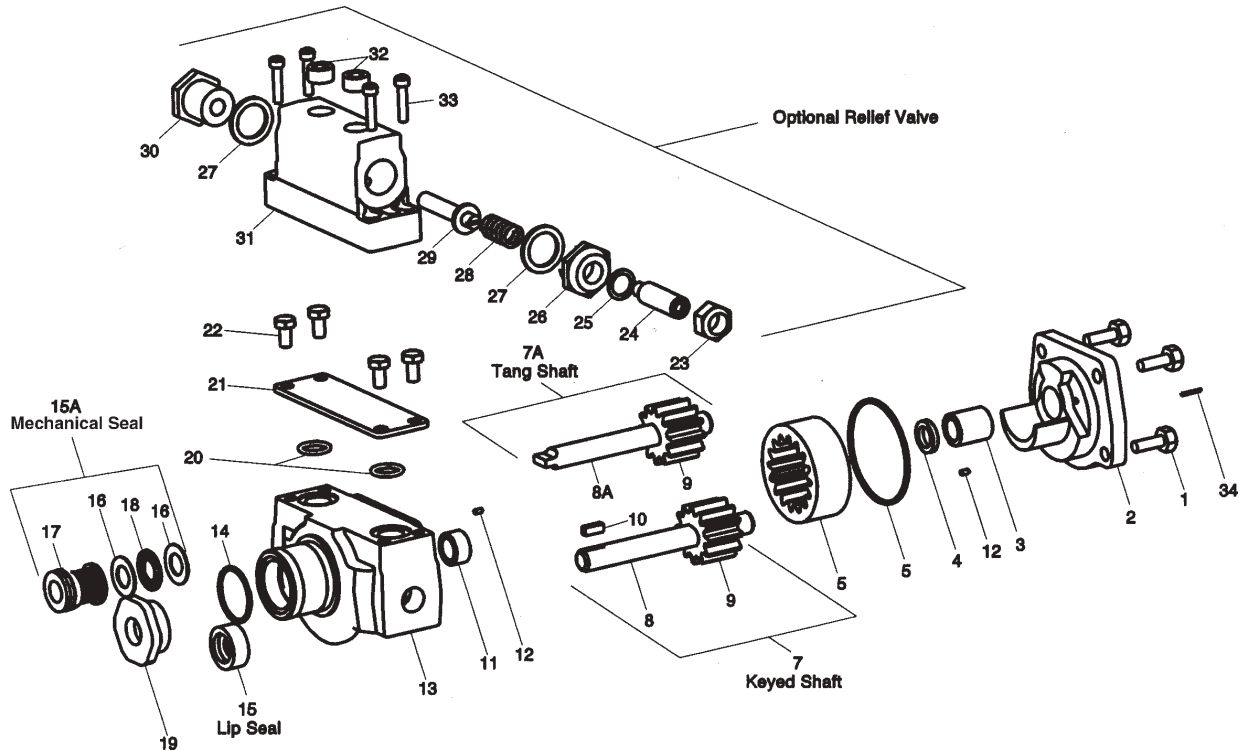

Item Number	Description	Qty Required
1	Screw-cover	4
2	Cover	1
3	Shaft bearing	1
4	Wiper Seal	1
5	O-Ring Cover	1
6	Rotor*-C.I.	1
7	Shaft & Pinion Assembly	1
7A	Tanged Shaft & Pinion Assy.	1
7B	Outboard Bearing Shaft & Pinion Assy. (Not shown)	1
8	Shaft Keyed(Not sold separately)	
8A	Shaft-Tang(Not sold separately)	
9	Pinion-Steel(Not sold separately)	
10	Key 1/8 sq. x 1/2" Long	1
11	Shaft Bearing	
12	Set Screw, Vent	1
13	Case 1/2" ports, D.I.	1
14	O-ring Gland	1
15	Lip Seal	
15A	Mechanical T-21 Seal	
16	Washer	2
17	Mechanical Seal	
18	Thrust Bearing	1
19	Gland	1
20	O-ring for cover/Relief Valve	2
21	Cover Plate	1
22	Screw-Cover Plate	4
23	Locking Nut	1
24	Adjustment Screw	1
25	Sealing Washer Std.	1
26	Bonnet	1

Item Number	Description	Qty Required
27	O-ring, Relief Valve	1
28	Spring Standard	1
29	Poppet	1
30	Cap	1
31	Relief Valve Body	1
32	Pipe Plug	2
33	Screw, Valve Body	4
34	Pin	1

## 6U & 8U Haight Pump w/o Relief Valve 6U & 8U Haight Pump with Relief Valve

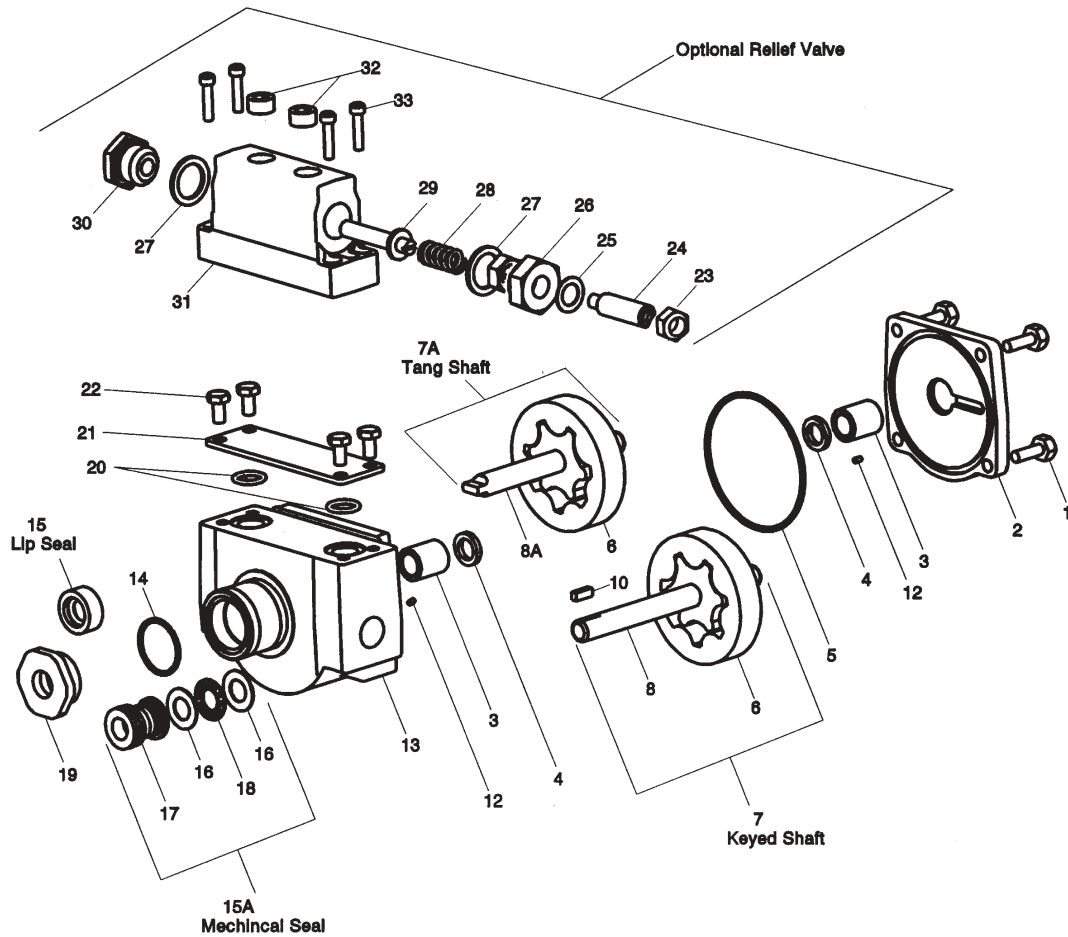

Item Number	Description	Qty Required
1	Screw-cover	4
2	Cover D.I.	1
3	Shaft bearing	2
4	Wiper Seal	1
5	O-Ring Cover	1
6	Gerotor Set	1
7 & 7A	Shaft & Gear Set Assembly	1
8	Shaft-Keyed (Not sold separately)	
8A	Shaft-Tang (Not sold separately)	
10	Key	1
12	Set Screw, Vent	1
13	Case 3/4" ports D.I.	1
14	O-ring Gland	1
15	Lip Seal	
15A	Mechanical Seal Package	
16	Washer	1
17	Mechanical Seal	
18	Thrust Bearing	1
19	Gland	1
20	O-Ring,Cover Plate or RV Body	2

Item Number	Description	Qty Required
21	Cover Plate D.I.	1
22	Screw, Cover Plate	4
23	Locking Nut	1
24	Adjustment Screw	1
25	Sealing Washer	1
26	Bonnet	1
27	O-ring, Relief Valve	2
28	Spring	1
29	Poppet	1
30	Cap	1
31	Relief Valve Body	1
32	Pipe Plug	2
33	Screw, Valve Body	4

# 10U through 40U Haight Pump w/o Relief Valve

## 10U through 40U Haight Pump with Relief Valve

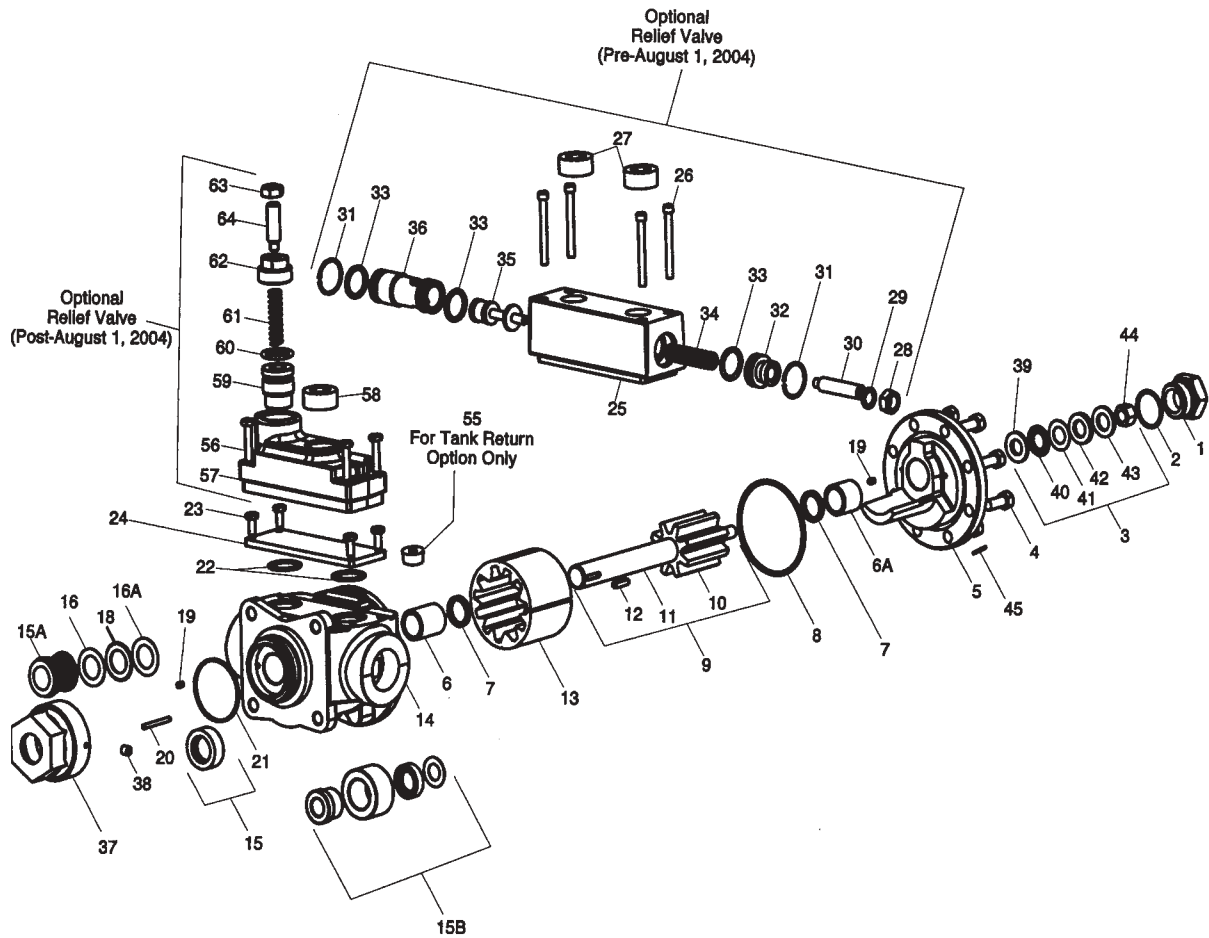

Item Number	Description	Qty. Required
1	Screw on Plug	1
2	O-Ring	1
3	Thrust Washer Kit	1
4	Screw	8
5	Cover	1
6&6A	Bearing	2
7	Wiper Seal	2
8	O-Ring-Cover	1
9	Shaft & Pinion Assy-std.	
10	Pinion (Not sold separately. Must order Item #9)	
11	Shaft (Not sold separately. Must order Item #9)	
12	Drive Key 3/16 Sq x 3/4" L	1
13	Rotor	
14	Case D.I.	1
15	Lip Seal	
15A	Mechanical Seal	
15B	Packing Seal	
16	Washer	1
16A	Washer	1
17	Gland	1
18	Thrust Bearing	1
19	Set Screw, Vent	1
20	Pin	1

Item Number	Description	Qty. Required
21	O-Ring, Gland	1
22	O-Ring, Cover Plate, Valve Body	2
23	Screw, Cover Plate	4
24	Cover Plate D.I.	1
25	Valve Body	1
26	Screw, Valve Body	4
27	Pipe Plug	2
28	Lock Nut	1
29	Washer	1
30	Adjustment screw	1
31	Retaining ring	2
32	Bonnet	1
33	O-ring, Valve-Buna	3
34	Spring-Std	1
35	Poppet	1
36	Cage	1
38	Set Screw, Gland	1
39	Washer	1
40	Thrust Bearing	1
41	Washer	1
42	Spherical Washer	1
43	Spherical Washer	1
44	Nut	1
45	Pin	1
55	Pipe Plug 3/4" NPT	1

## 44D through 80D Double Pump

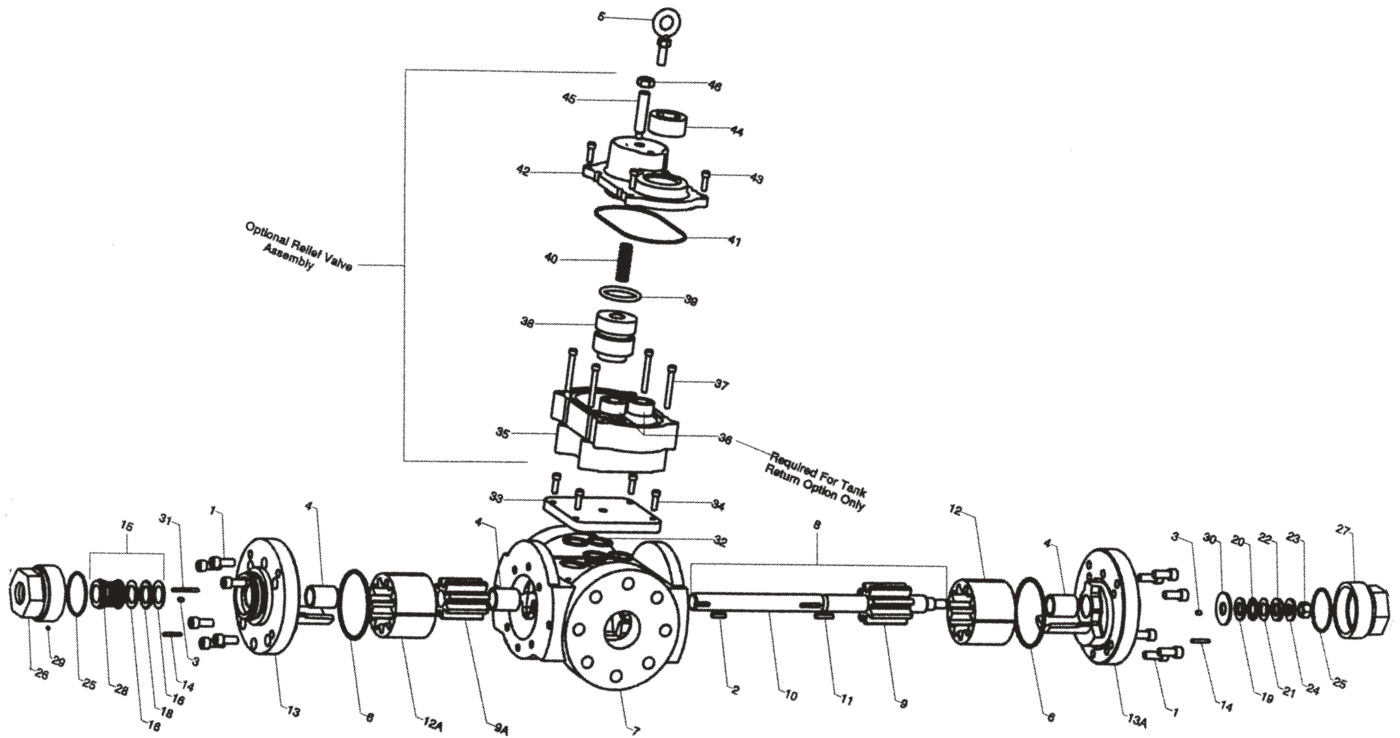

Item Number	Description	Qty Required	Item Number	Description	Qty Required
1	Screw .375 x .875 UNC HSCS	12	32	O-ring	4
2	Drive Key .188 x .75	1	33	Cover Plate	1
3	Set Screw 10-32x1/4 SH CP	2	34	Screw, Cover Plate	4
4	Shaft Bearing .877 x 1.5 x 1.128	3	35	Valve Body	1
5	Eyebolt	1	36	Pipe Plug	2
6	O-ring	2	37	Screw, Valve Body	4
7	Casing D.I.	1	38	Valve Piston	1
8	Shaft & Pinion Assembly	1	39	O-ring, Valve Piston	1
9	Standard Pinion (Not sold separately. See Item #8)		40	Spring	1
9A	Keyed Pinion (Not sold separately. See Item #8)		41	O-ring, Valve cover	1
10	Shaft (Not sold separately. See Item #8)		42	Valve Cover	1
11	Key, Pinion - .188x 1.0	1	43	Screw, Valve cover	4
12	Rotor C.I.	1	44	Pipe Plug	1
12A	Mating Rotor C.I.	1	45	Adjustment Screw	1
13	Drive Plate D.I.	1	46	Lock Nut	1
13A	Cover D.I.	1			
14	Roll Pin .156x1.13	2			
15	Seal Kit (See Seal Kits-Page 22)	1			
16	Washer .625x1.12x.094	2			
18	Thrust Bearing (Keyed end) (.875)	1			
19	Washer (1.12 x .63 x .09 hard steel)	1			
20	Thrust Washer (.625)	1			
21	Washer (1.12 x .63 x .03 hard steel)	1			
22	Washer	1			
23	Locking Nut	1			
24	Washer	1			
25	O-ring-Gland	2			
26	Gland cap-shaft	1			
27	Gland cap	1			
28	Mechanical shaft seal				
29	Set Screw 10-32x1/4 SH CP	1			
30	Washer .656x1.66x.094	1			
31	Roll Pin	1			

# 10 - 40 gal. Barrier Seal HAIGHT® Pump with or without Relief Valve

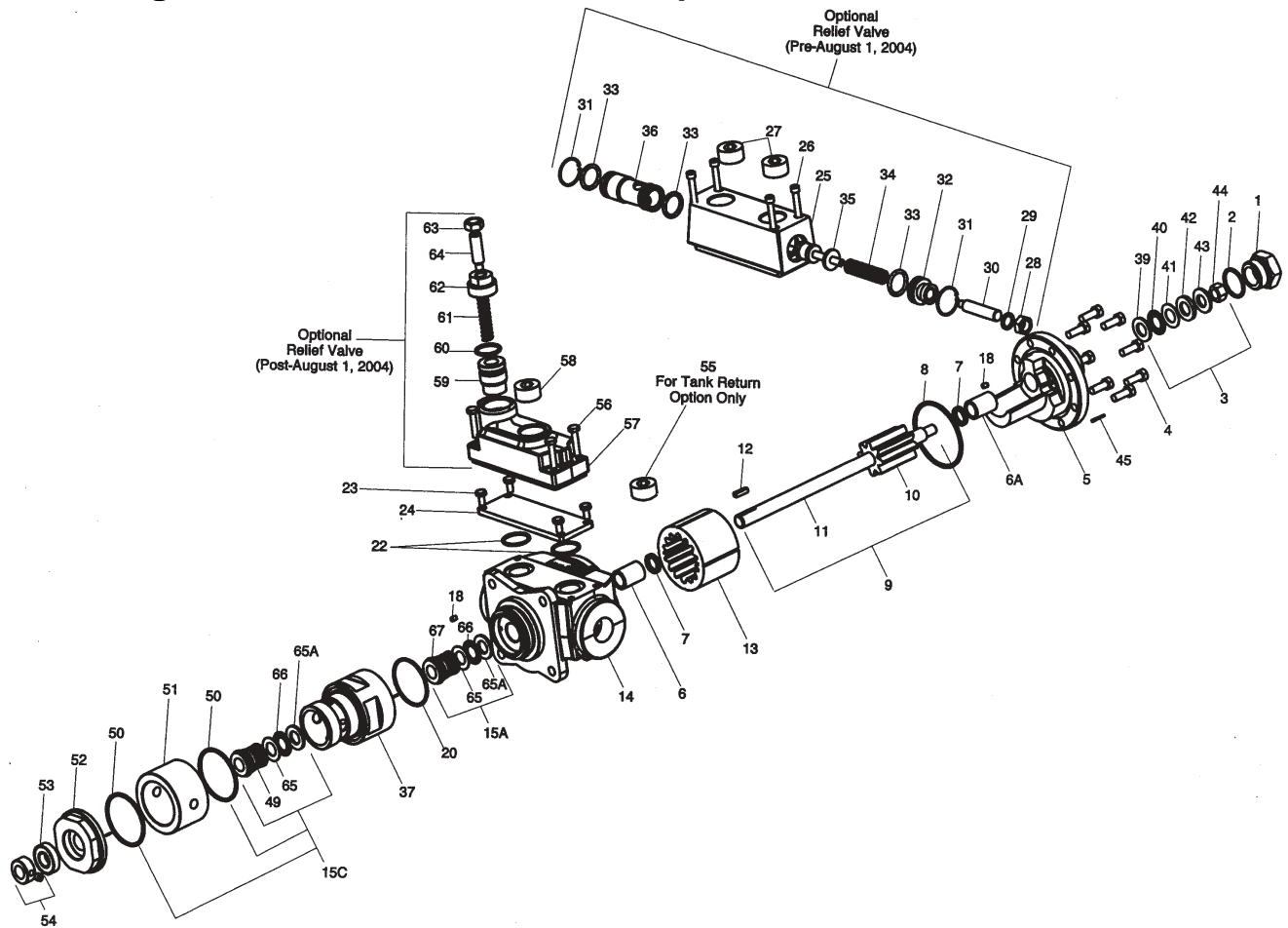

Item No.	Description	Qty.
1	Screw on Plug	1
2	O-Ring	1
3	Thrust Washer Kit	1
4	Screw	8
5	Cover	1
6&6A	Bearing	2
7	Wiper Seal	2
8	O-Ring-Cover	1
9	Shaft & Pinion Assy	1
10	Pinion	1
11	Shaft	1
12	Drive Key	1
13	Rotor	1
14	Case D.I.	1
15	Lip Seal	1
15A	Mechanical Seal	1
15B	Packing Seal	1
16	Washer	1
16A	Washer	1
17	Shaft Seal	1
18	Thrust Bearing	1
19	Set Screw, Vent	1
20	Pin	1
21	O-Ring, Gland	1
22	O-Ring, Cover Plate, Valve Body	2
23	Screw, Cover Plate	4
24	Cover Plate	1

Item No.	Description	Qty.
25	Valve Body	1
26	Screw, Valve Body	4
27	Pipe Plug	2
28	Lock Nut	1
29	Washer	1
30	Adjustment screw	1
31	Retaining ring	2
32	Bonnet	1
33	O-ring, Valve-Buna	3
34	Spring-Std	1
35	Poppet	1
36	Cage	1
37	Gland	1
39	Washer	1
40	Thrust Bearing	1
41	Washer	1
42	Spherical Washer	1
43	Spherical Washer	1
44	Nut	1
45	Pin	1
49	Shaft Seal, Secondary	1
50	O-ring, Sleeve	2
51	Sleeve	1
52	Gland	1
53	Roller Bearing	1
54	Locking Collar	1
55	Pipe Plug 3/4" NPT	1

## Haight Sales Policy and Warranty

All quotations and sales are subject to the following terms and conditions and those contained on the face hereof. Baker's Haight and Monitor Divisions ("Baker") are bargaining for and will do business only on the terms and conditions on this form.

1. **ACCEPTANCE AND FILLING OF ORDERS; CONTRARY TERMS; ENTIRE AGREEMENT** - All orders for goods and materials are subject to acceptance by Baker at its orders for goods and materials are subject to acceptance by Baker at its applicable Monitor or Haight Division office. **BUYER'S ORDER IS ACCEPTED ONLY ON THE TERMS AND CONDITIONS CONTAINED HEREIN AND THE PROVISIONS OF ANY PURCHASE ORDER OR OTHER WRITING INCONSISTENT HEREWITH SHALL NOT CONSTITUTE A PART OF THE CONTRACT OF SALE.** Baker's acceptance is conditional on Buyer's assent to these terms and conditions and if any of these terms and conditions are not acceptable to Buyer, Baker must be notified promptly. This writing is intended also as a complete and exclusive statement of the terms and conditions thereof and that a contract be formed between the parties. No modification of any term or condition will be valid or binding upon Baker unless approved by Baker in writing by Baker's duly authorized personnel. The authority of Baker's agents is limited to solicitation of orders and collection of debts.

2. **PRICES** - Prices are F.O.B. factory, except that goods to be shipped outside the United States are F.O.B. destination for the Monitor Division only. Unless specifically held open for a length of time on Baker's Quotation form, all Price Lists, Discount Schedules, other Promotional Programs, and Freight Allowances are subject to change without notice. Any unshipped balances on Buyer's purchase orders will be invoiced to and paid by Buyer at prices in effect at the time of delivery. Orders based on quotations shall specify the quotation number.

3. **MINIMUM INVOICE** - Unless otherwise agreed, a minimum charge of \$50.00 net will be charged on each purchase to cover packing, shipping, order processing, billing and other handling expenses:

4. **QUOTATIONS** - Quotations are good for 45 days from the date of quotation, unless otherwise stated.

5. **PAYMENT TERMS** - Terms of sale are as stated in the current applicable Catalogs, Price Lists, Discount Schedules, Promotional Programs, and Special Sales Terms. All orders are subject to approval of Baker's credit department. Baker reserves the right to require payment in advance or C.O.D., or to otherwise modify credit terms. For Monitor Division Buyers, a finance charge of 1.5% per month, which is an annual percentage rate of 18% per year, will be charged on past due accounts.

6. **CATALOGS AND PRICE LISTS** - Goods and materials reflected in Baker's Catalogs, Price Lists, Discount Schedules and Special Sales Terms are subject to change at any time and may not be kept in stock. Baker shall not be liable for any errors or omissions in its Catalogs, Price Lists, Discount Schedules, and Special Sales Terms.

7. **DELIVERY DATES** - Shipment, delivery and all other dates are estimates only, and shall be subject to, and contingent upon, strikes, labor difficulties, riot, war, fire, delay or defaults of common carriers, failure or curtailment in Baker's usual sources of supply, governmental decrees or orders, or without limiting the foregoing, any other delays beyond Baker's reasonable control, and Baker shall not be liable for any loss or damage arising therefrom. Any delivery not in dispute shall be paid for regardless of other delivered or undelivered merchandise.

8. **CANCELLATION** - Orders received and accepted by Baker are firm contracts and Buyer any cancel only with Baker's written consent and upon payment of reasonable cancellation charges, including reimbursement of Baker's direct costs incurred, normal, indirect and overhead charges and a normal profit.

9. **RESTOCKING CHARGES** - Goods may be returned only when specifically authorized by Baker. Buyer shall be charged a minimum of 15% for restocking or handling charges, plus any further expense incurred in freight or manufacturer return charges. However, the restocking charge will not apply if Baker authorizes the return of goods as defective.

10. **IMPROVEMENTS AND SPECIFICATIONS** - Manufacturers and Baker are constantly improving the design, construction and quality of their products and Baker accepts no liability for any difference between the catalog illustration and the furnished product to Buyer. All specifications and engineering data provided to Buyer are provided in good faith and Buyer agrees to hold Baker harmless and indemnify Baker for any damages, losses, or expenses arising from specification changes, inaccurate specifications or from functional failures.

11. **SHIPPING POLICIES AND CLAIMS** - All freight allowances will be in accordance with the applicant freight policy outlined in Baker's Discount Schedules and Freight Allowances. Baker reserves the right to ship via the most economic transportation means, routing of the shipment, and to select the point or origin for the shipment. On goods to be shipped outside the United States, for the Monitor Division only, title shall pass upon delivery at the agreed upon destination. These shipments will be in accordance with the provisions of form AD39, Baker Mfg. Co./Monitor Division Terms, Discounts & Freight Policy. On all other goods delivered by Common Carrier, title shall pass upon delivery to the Carrier, and Baker accepts no liability for breakage, damage, hidden or otherwise, delay or shortage after goods are delivered to the Carrier. On goods delivered by Common Carrier, all claims for shortages or damages must be made directly to the Carrier within seven days following the delivery of goods. On goods delivered by Baker trucks, all claims for shortages or damages must be made to Baker in writing within seven days following the delivery of goods, Baker will not be responsible for material shortage claims for deliveries to unattended sites.

12. **FREIGHT CHARGES, FEES, AND TAXES** - In addition to the stated prices, Buyer will reimburse Baker for sales tax, use tax or any other tax which Baker must, at any time, either pay or be required to collect by reason of the sale of goods and/or services to Buyer. Buyer is also responsible for all freight charges, if applicable, except on goods to be shipped outside the United States. Whenever applicable, taxes or freight charges will be added to the invoice as a separate charge to be paid by the Buyer. Buyer will also pay Baker any collection fees and reasonable attorneys fees incurred by Baker in enforcing this agreement or defending against any claim for breach of this agreement.

13. **APPLICABLE FEDERAL LAWS** - Baker and Buyer will Comply with all federal laws, and regulations issued pursuant to such laws, which govern Baker's and Buyer's performance hereunder.

14. **WARRANTY PROVISIONS** - For Haight Division Buyers, Baker warrants the goods manufactured by it to be free from defects in material or workmanship under normal use and service, for a period 90 days from the date of start-up or one year from the date of shipment, whichever comes first. Goods through normal use that become unusable within one year are warranted only as to defaults in material or workmanship for 90 days from the date of startup.

For Monitor Division Buyers, Baker warrants the goods manufactured by it to be free from defects in material or workmanship under normal use or service, for a period of one year from date of shipment.

This warranty does not apply to goods or parts not manufactured by Baker, instead Baker's obligation for these goods or parts is limited to the actual warranty extended to Baker by the manufacturer.

All warranties herein are void and do not apply if: 1) the goods or parts have been altered or repaired by others; 2) the goods have not been installed or used in accordance with any applicable instructions or limitations provided by Baker, or the manufacturer of the good or part; 3) the goods or parts have not been installed or used in accordance with the goods' or parts' normal use and service; or 4) the goods are used in nuclear facility applications.

**BAKER MAKES NO OTHER EXPRESS OR IMPLIED WARRANTIES OF ANY KIND WITH RESPECT TO THE GOODS, PARTS AND MATERIALS, INCLUDING BUT NOT LIMITED TO, ANY IMPLIED WARRANTY AS TO MERCHANTABILITY OR AS TO THE FITNESS OF THE MERCHANDISE FOR A PARTICULAR USE AND SHALL NOT BE LIABLE FOR ANY LOSS OR DAMAGE, DIRECTLY OR INDIRECTLY, ARISING FROM THE USE OF SUCH MERCHANDISE OR FOR CONSEQUENTIAL DAMAGES.**

15. **RETURN OF GOODS OR MATERIALS; LIMITATION OF REMEDIES** - Baker must be given notice of any rejection of the goods or parts within 7 days of Buyer's receipt of the goods or parts with respect to which the claim is being made, and prior to the goods or parts being returned. As to any warranty claim made after Buyer's acceptance of the goods, Buyer must notify Baker of the warranty claim within seven days of discovery of the claim, and prior to return of the goods or parts. No goods or parts shall be returned without Baker's approval and the authorization number given to Buyer by Baker. All returned goods or parts must be accompanied by necessary warranty information and are subject to inspection by Baker before any repair, replacement or credit, at Baker's option, will be issued. Baker's liability and Buyer's sale and exclusive remedy for any claim against Baker will be limited to repair, replacement and or credit, at Baker's option, with respect to goods returned to Baker at Buyer's expense. Any goods or parts which have been defaced, altered or worked upon in any way, will not be subject to repair, replacement or credit.

16. **EXCLUSION OF CONSEQUENTIAL AND INCIDENTAL DAMAGES; EXCLUSION OF TORT REMEDIES — BAKER WILL NOT BE LIABLE, UNDER ANY CIRCUMSTANCES FOR CONSEQUENTIAL OR INCIDENTAL DAMAGES, INCLUDING, BUT NOT LIMITED TO, LABOR COSTS OR LOST PROFITS RESULTING FROM THE USE OF OR INABILITY TO USE THE GOODS OR MATERIALS.** This is a commercial, sales transaction. The parties wanted to be governed by Article 2 of the Uniform Commercial Code and related Commercial Legal Principles. **NEITHER PARTY WILL HAVE ANY NEGLIGENCE OR OTHER TORT LIABILITY TO THE OTHER OR TO ANY THIRD PARTY, ARISING FROM ANY BREACH OF THIS AGREEMENT.** It is intended by the parties that the exclusion of consequential and incidental damages and tort remedies are separated and distinct from any limitation of remedies provided hereunder.

17. **LAW OF AGREEMENT** - All disputes under this agreement shall be settled in accordance with the laws of the State Of Wisconsin, including the Uniform Commercial Code.

18. **PROPRIETARY DATA** - Unless otherwise specifically agreed in writing by an officer of Baker's, neither Buyer nor any other person, shall have any right to examine or audit Baker's books, cost accounts or records of any kind or on any matter, or be entitled to, or have control over, any engineering or production prints, drawings or technical data which Baker in its sole discretion, may consider in whole or in part proprietary to itself.

19. **SET OFF** - Baker may set off any amount due to Buyer, whether or not under this agreement, against any amount that may become due from Buyer hereunder.

20. **CONTROLLING PROVISIONS** - These terms and conditions shall supersede any provisions, terms and conditions contained on any order, or other writing the Buyer may give or receive and the rights of the parties shall be governed exclusively by the provisions, terms and conditions hereof. Baker makes no representations or warranties concerning this order except such as are expressly contained herein, and this order may not be changed or modified orally.

21. **NON-WAIVER** - Failure of Baker to enforce any of these conditions or exercise any right accruing through the default of the Buyer shall not affect or impair Baker's rights in case such default continues or in case of any subsequent default of the Buyer and such failure shall not constitute a waiver of other or future defaults of the Buyer.

Revised 1-2-03



## ORDERING/QUOTATION INFORMATION

We want to serve you quickly and efficiently. When you order, please be sure to give us the pump model number and quotation reference number. For quotations please provide as much of the following information as possible:

- liquids you will be pumping
- flow rate
- operating pressure
- suction conditions
- temperature
- duty cycle
- seal type
- bearing information
- operating speed
- pump rotation
- port position
- alternative rotor
- special instructions



*Pumps That Perform.*

*Pumps That Fit.*

### If You Have Any Questions

Please call Baker Manufacturing at (800) 871-9250 for our nearest distributor.

### **Baker Manufacturing Company**

133 Enterprise Street  
Evansville, WI 53536  
(608) 882-5100  
**(800) 871-9250**  
Fax (608) 882-3777  
E-mail: [haight@baker-mfg.com](mailto:haight@baker-mfg.com)  
Website: [www.haightpump.com](http://www.haightpump.com)