

**Are leaking shaft
seals giving you
nightmares,
or worse?
Haight has Answers!**

Our revolutionary new Barrier Seal Design provides a simple, flexible, and *effective* method to both monitor and contain shaft seal leaking!

Simple – The Barrier Seal uses two independent sealing elements, contained in isolated chambers, one for the pumped fluid and one for the selected barrier fluid. The entire assembly simply screws onto any 10 through 80gpm Haight U Series pump with no special tools or machining required. The use of two independent, commonly available seals significantly reduces initial cost and repair expense.

Flexible – The Barrier Seal will accept Type 21, Type 2, Type 9, and Type 2B (special order) seal configurations, in 9 different elastomers. The barrier fluid ring rotates freely to adapt to most flush configurations.

Effective – Two independent sealing elements dramatically reduce the risk of shaft seal leakage creating a contamination risk or safety hazard. Ability to monitor seal performance allows pump users to detect impending seal failure, and perform preventive maintenance *before* catastrophic failure occurs! The use of commonly available seal designs means readily available repair components virtually anywhere in the world.



133 Enterprise Street
Evansville, WI 53536
Phone: 800-871-9250
Fax: 608-882-3777

Email: haight_pump@baker-mfg.com

THE HAIGHT ADVANTAGE

Your local Haight distributor is a pump professional with the products, knowledge, and experience to provide quality solutions to all your pumping needs.



**BARRIER
SEAL
DESIGN**

Simple, Flexible and
Effective
Fluid Containment

www.haightpump.com

Pumps that fit . . . Pumps that perform

Barrier Seal Design Features:

Inner housing simply screws onto the U Series housings, and seals with dependable captured, static o-ring seal. The Haight Barrier Seal design can be ordered from the factory, or retrofitted in the field with no special tools or machining required.

Barrier Fluid Ring rotates through 360° to readily meeting various flushing arrangements.

Large nut End Cap design allows easy access for maintenance, and adjustment of the Barrier Fluid Ring.

Sealed, lubricated, radial bearing provides shaft stability and ensures proper alignment for the seals.

Hardened, precision ground, stress proof steel shaft provides years of dependable service even under the most demanding service.

Four (4) types of Barrier Fluid Seals and nine (9) elastomer selections allow for operating conditions to 650°F and 650psid.

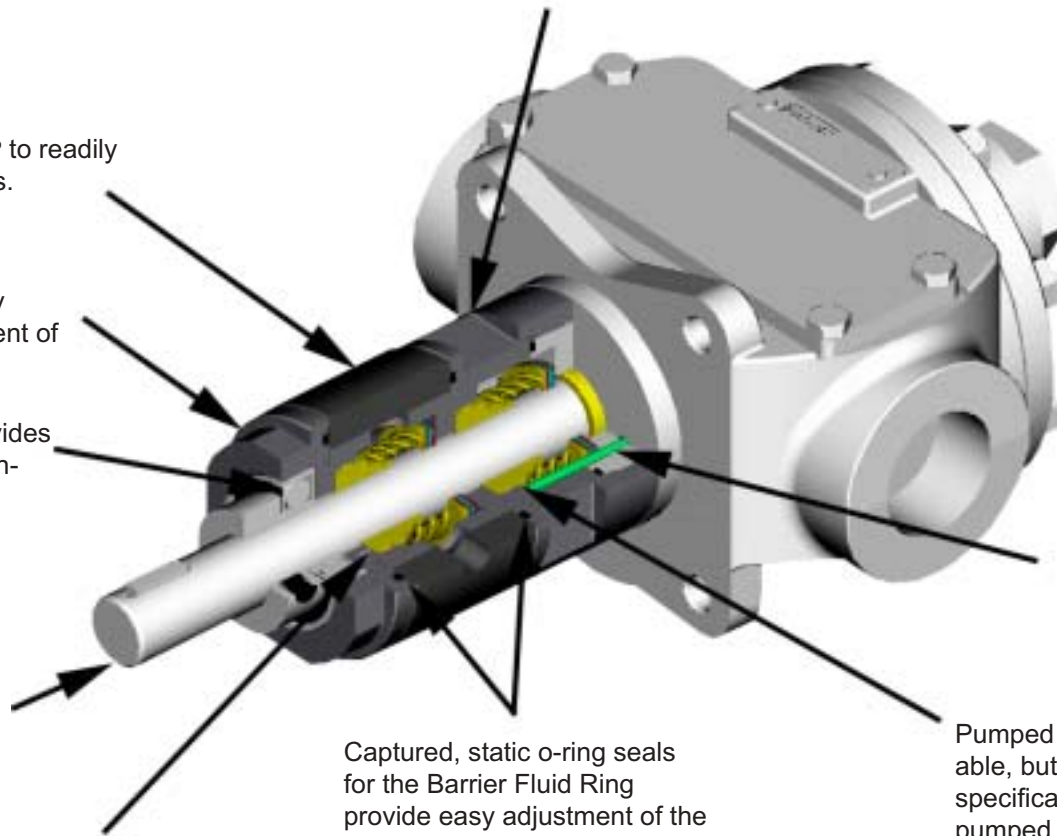

Captured, static o-ring seals for the Barrier Fluid Ring provide easy adjustment of the ring and secure sealing.

Seal Cavity Venting, is a standard feature on Haight U Series pumps. Venting to the suction side of the pump enhances cooling and lubrication of the seal, extending seal life. Seal vents can be easily changed in the field with no special tools required.

Pumped Fluid Seal, same variety available, but the seal can be configured to specifically meet the requirements of the pumped fluid.